

701 92-0440

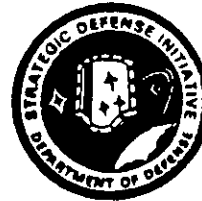

# Fact Sheet



Strategic Defense Initiative Organization  
External Affairs Office, Room 1E1020, The Pentagon, Washington, D.C. 20301-7100

Phone (703) 693-1777

Fax (703) 693-1706

## Infrared Background Signature Survey (IBSS)

Description: IBSS is a Strategic Defense Initiative Organization (SDIO) program aboard the STS-39 space shuttle mission involving a set of experiments designed to perform critical data collections with emphasis on liquid engine plume, earth background, and chemical obscurant phenomenology. IBSS involves the use of the Shuttle Pallet Satellite (SPAS) integrated to support a cryogenically cooled infrared radiometer and spectrometer, ultraviolet and visible spectrographs and imagers, and Low Light Level Television systems. The SPAS spacecraft with the IBSS instruments will be deployed from the Shuttle and retrieved.

The IBSS instruments will observe Shuttle Orbital Maneuvering System (OMS) engine and Primary Reentry Control System (PRCS) engine firings, the hard earth and earthlimb, contaminant environment surrounding the Orbiter, and chemicals and gasses released from subsatellites and systems mounted in the shuttle bay.

Status: IBSS is manifested on STS-39, scheduled to be launched from Kennedy Space Center on 26 February 1991 and will return to Edwards AFB on 5 March 1991.

### Experiment Synopses:

#### Shuttle Engine Plumes

Firings of the OMS and RCS engines create plumes which resemble those which are produced by systems of interest. Measurements will include radiometric spectral, spatial and temporal measurements in the appropriate regions of the infrared, ultraviolet and visible spectrums.

#### Earthlimb and Hard Earth

Space-based infrared sensor systems will encounter radiation from the earthlimb and hard earth. Measurements will include radiometric spectral, spatial and temporal measurements in the appropriate regions of the infrared spectrum.

#### Chemical Release Observation (CRO)

The multi-spectral signatures of chemicals which may be released in space by vehicles of interest as obscurants need to be characterized. Spectral, spatial and temporal measurements will be taken of the chemical "cloud".

#### Spacecraft Environment

A "glow" around the Orbiter has been observed in the visible wavelength. Multispectral signatures will be characterized in order to understand this contaminant environment and the atmospheres expected to surround future space-based sensor systems.

Gas Release - Critical Ionization Velocity (CIV)

Theoretical studies have predicted that neutral gaseous molecules will be ionized when they travel through a plasma at velocities such that their kinetic energies exceed their ionization potentials. If correct, such ionization will provide additional observables on objects of interest. Radiometric spatial, spectral and temporal measurements will be taken of released gasses.

Major Participant:

SDIO Sensors and Technology Office

Program management, funding and development of the IBSS program.

Cooperating Agencies:

Messerschmidt-Bolkow-Blohm (MBB)

Refurbishment and integration of the SPAS spacecraft, and development of the cryogenically cooled infrared sensor.

U.S. Air Force Space Division

Shuttle integration.

Air Force Geophysical Laboratory

Instruments and experiments.

University of Arizona

Arizona Imaging Spectrometer (AIS)

Utah State University

Portable Calibration System.

Status

The IBSS payloads - SPAS, CRO and CIV - have completed integrated depreciation tests with the space shuttle Discovery.

current as of 10 JAN 1991

11192-04169

# **STRATEGIC DEFENSE INITIATIVE**

## **Infrared Background Signature Survey (IBSS) Program**



**23 APR 91**

**Ambassador Henry Cooper, SDIO Director  
Dr. Michael Griffin, SDIO Deputy For Technology  
Mr. Michael Harrison, IBSS Program Manager**

**For More Information Contact SDIO News Branch At (703) 695-8743**



# STS-39 FLIGHT OVERVIEW

**Vehicle:** Discovery

**Cargo:**

- IBSS
  - SPAS II
  - IRS
  - AIS
  - L<sup>3</sup> TV
  - CRO
  - CIV
- Air Force Payload (AFP - 675)
- Space Test Payload (STP - 1)

**Altitude:** 140 nm

**Inclination:** 57°

**Flight Duration:** 8 Days

**Launch Date:** 23 APR 91

## Modes Of Operation

- In Bay
- At RMS
- Detached
  - Near Field (2.25 km)
  - Far Field (10 km)

**Crew Size:** 7 (Dual Shift)

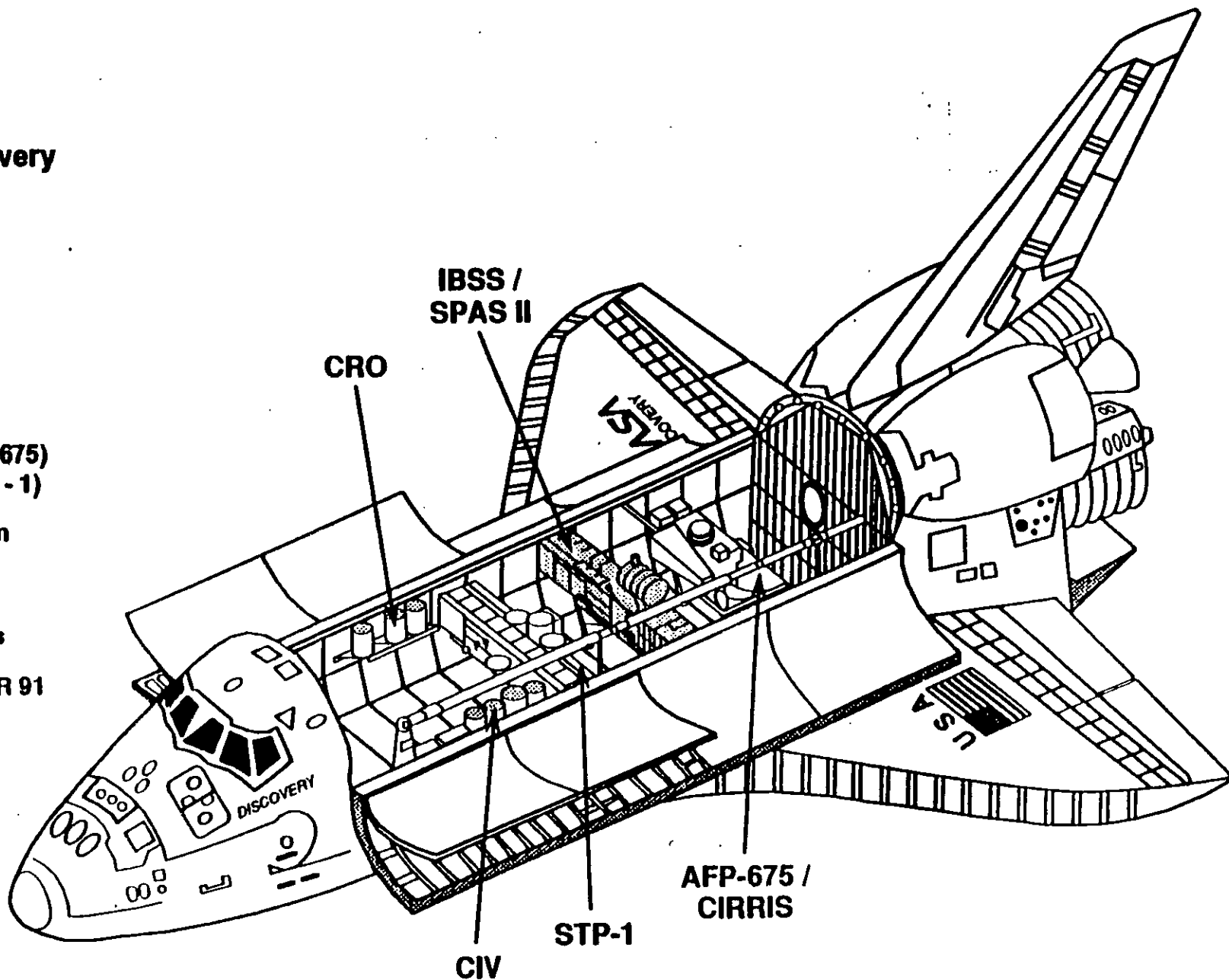



# IBSS: INFRARED BACKGROUND SIGNATURE SURVEY

---

## *Mission Objective*

**Acquisition Of Data For Design Of Advanced Sensor Systems**

## *Measurement Objectives*

- **Orbiter Plumes**
  - Orbiter OMS & RCS Plumes
  - Core & Total Exhaust
- **Earth**
  - Spatial & Temporal Structure From 30-100 km Tangent Height
  - Earth Scan, Terminator & Solar Specular Point
- **Chemical Release**
  - Signatures Of Propellants Released From Subsatellites
- **Gas Release**
  - Signatures Of Gas After Released From Orbiter
- **Orbiter Environment**
  - Contaminants & Glow
  - Orbiter Activities (Water Dump, Flash Evaporator & RCS Firings)
- **In-Flight Verification**
  - Signatures Of Celestial Sources
  - Sensor Performance Verification
  - Ground Truth



UNCLASSIFIED

# IBSS MISSION SCENARIO

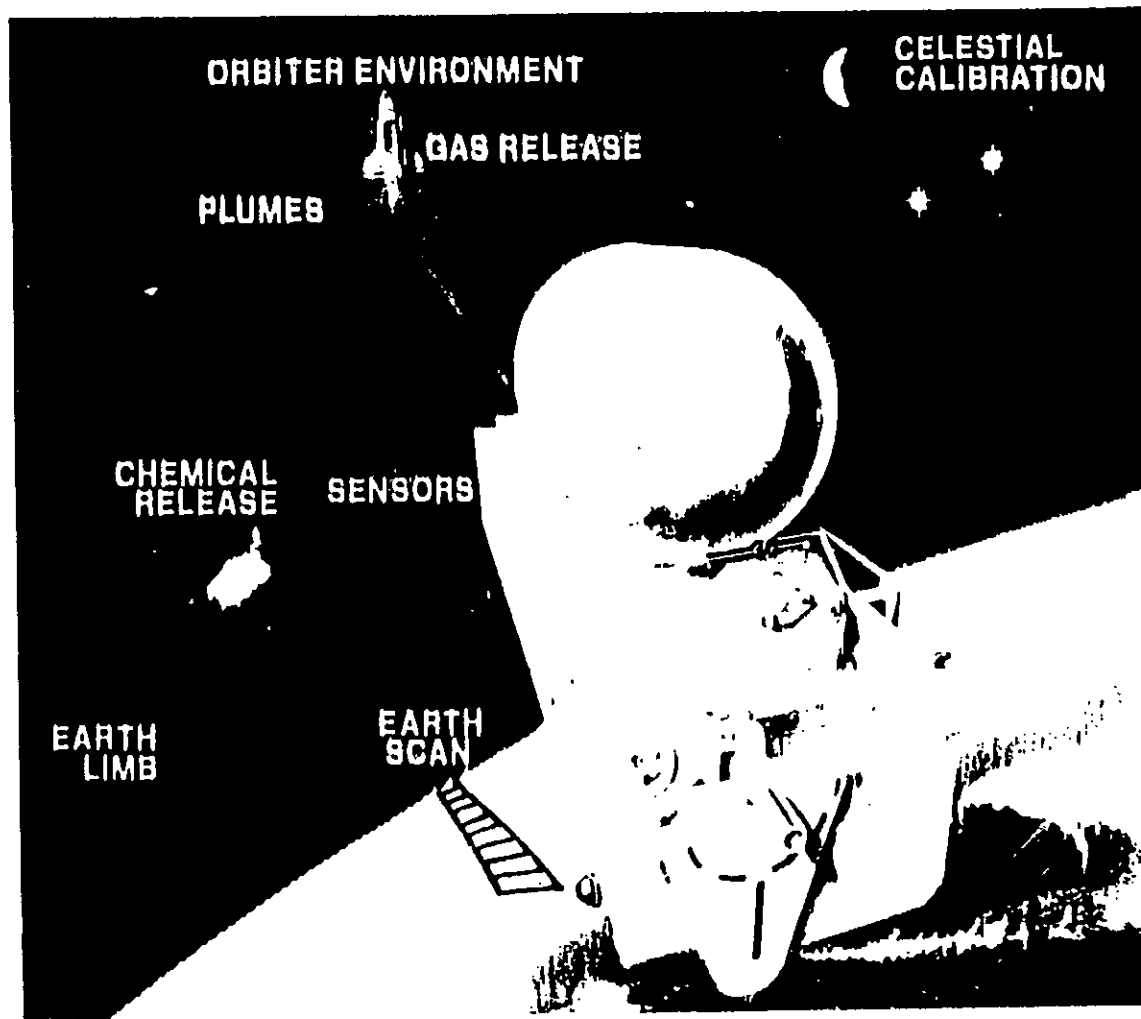

UNCLASSIFIED

87U-1105-1  
4 Dec 89

FOI 92-0440

UNCLASSIFIED

**STRATEGIC DEFENSE INITIATIVE  
INFRARED BACKGROUND SIGNATURE SURVEY INITIAL RESULTS  
PRESS CONFERENCE**

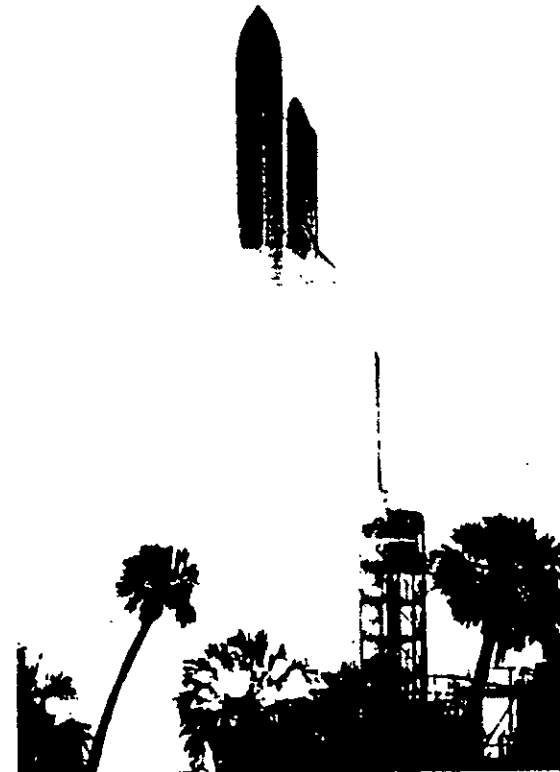

OCTOBER 1991

**SENSORS DIRECTORATE  
STRATEGIC DEFENSE INITIATIVE ORGANIZATION**

UNCLASSIFIED

91U-0548/4  
15 OCT 91



UNCLASSIFIED

# OUTLINE

- MISSION OVERVIEW
- SUMMARY OF RESULTS
- INDIVIDUAL EXPERIMENT RESULTS/DATA
- MISSION OPERATION
- IBSS PROGRAM COMMENTS
- FUTURE MISSION (SPAS-III)
- SUMMARY

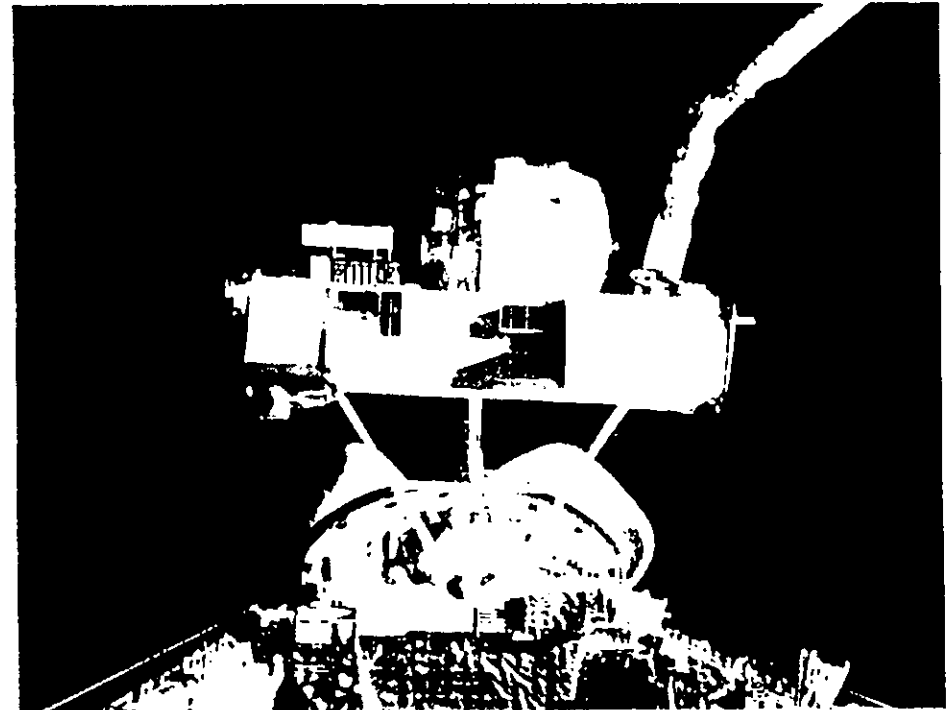

UNCLASSIFIED

910-1247  
15 OCT 91





UNCLASSIFIED

# STS-39 FLIGHT OVERVIEW

**VEHICLE:** DISCOVERY

**CARGO:**

- IBSS
  - SPAS II
    - IRS
    - AIS
    - L<sup>3</sup> TV
  - CRO
  - CIV
- AIR FORCE PAYLOAD (AFP-675)
- SPACE TEST PAYLOAD (STP-1)

**ALTITUDE:** 140 NM

**INCLINATION:** 57°

**LAUNCH DATE:** 28 APR 91

**MODES OF OPERATION**

- IN BAY
- AT RMS
- DETACHED
  - NEAR FIELD (2.25 KM)
  - FAR FIELD (10 KM)

**CREW SIZE:** 7 (DUAL SHIFT)

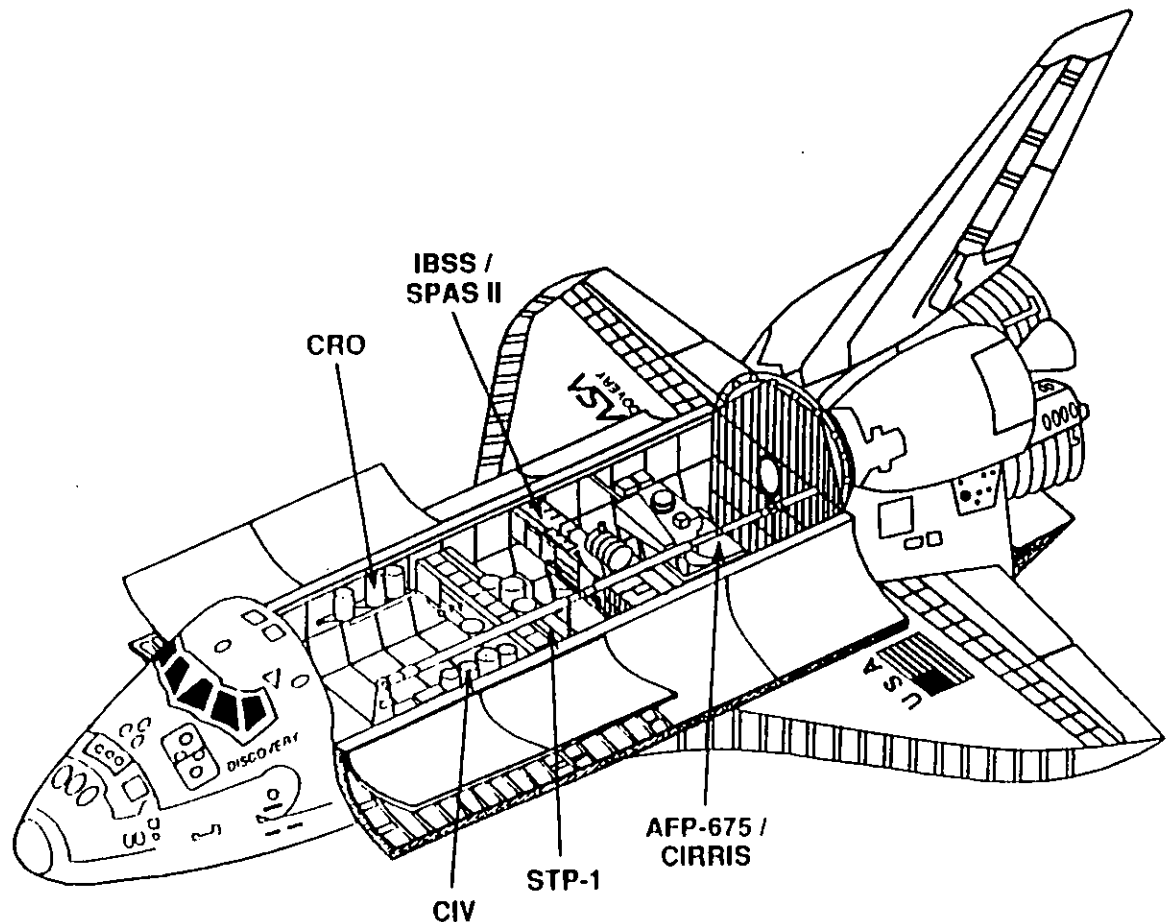



UNCLASSIFIED

# STS-39 MISSION OVERVIEW

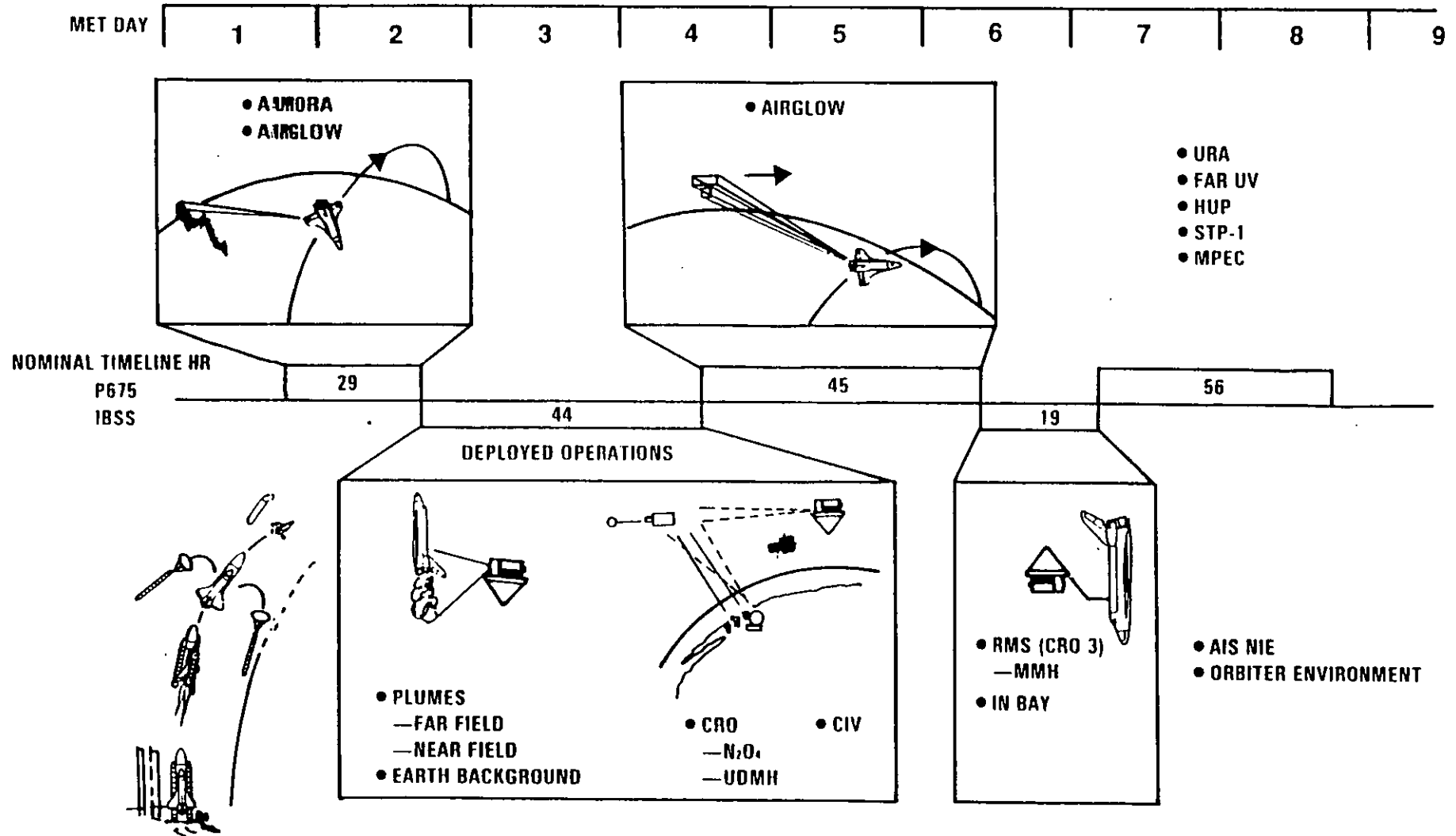

UNCLASSIFIED

UNCLASSIFIED



## MISSION RESULTS OVERVIEW

---

- **LAUNCHED ON STS-39**
- **MISSION DURATION: 28 APRIL - 8 MAY**
- **HIGHLY SUCCESSFUL; COMPLETED 49 OF 53 PLANNED EXPERIMENTS**
  - **PERFORMED SEVERAL ADDITIONAL UNPLANNED EXPERIMENTS**
  - **NUMEROUS CALIBRATION MEASUREMENTS (HIGH DATA QUALITY)**
- **DATA QUALITY EXCEPTIONAL, SYSTEM EXCEEDED PERFORMANCE**
- **LOW COST/HIGH UTILITY MISSION**

UNCLASSIFIED

01U-05501  
8 Sep 01



UNCLASSIFIED

# PLUME MEASUREMENT

ORBITER

OBJECTIVE:  
COLLECT MANY PLUME SAMPLES

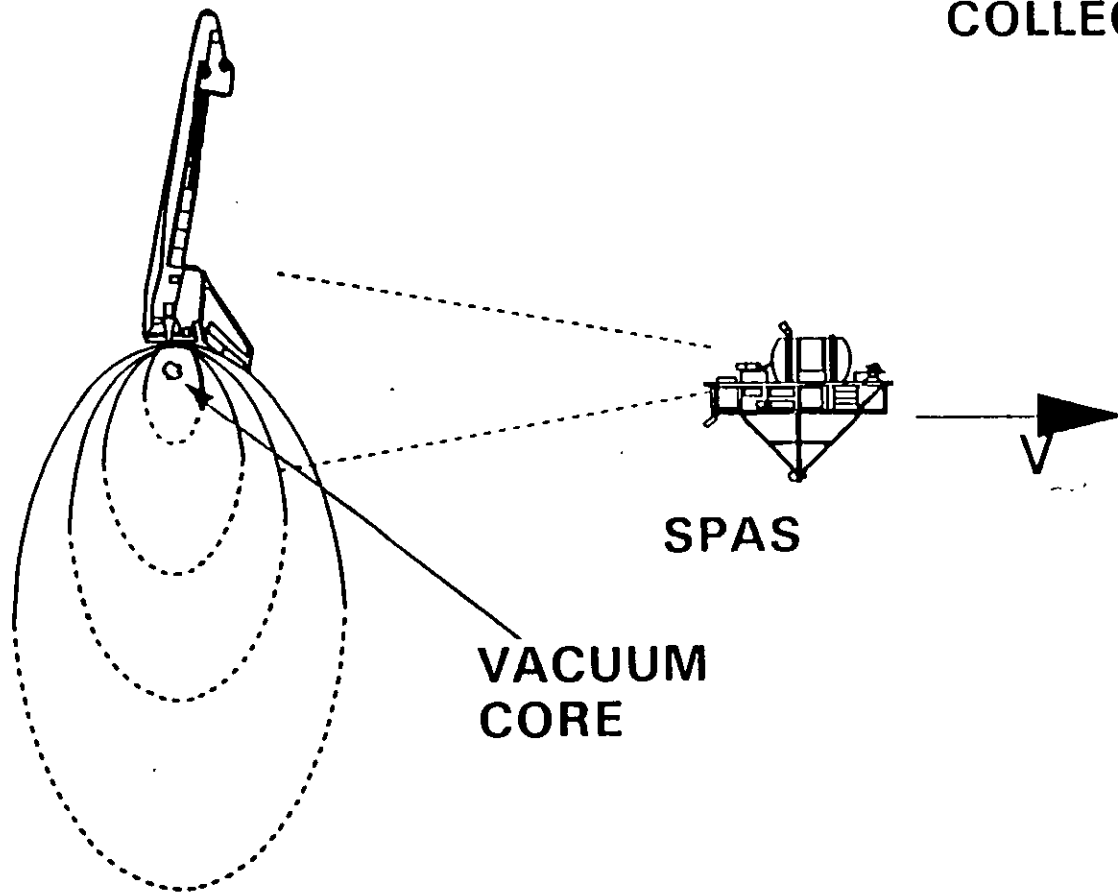

SPAS

VACUUM  
CORE

RESULT:  
12 PLANNED (6 REQ'D,  
6 DESIRED)  
17 COLLECTED

PLUME ← NF (1.2 MILES) →  
← FF (6.2 MILES) →

UNCLASSIFIED



# IBSS FAR FIELD OMS PLUME DATA

T = 0 SEC

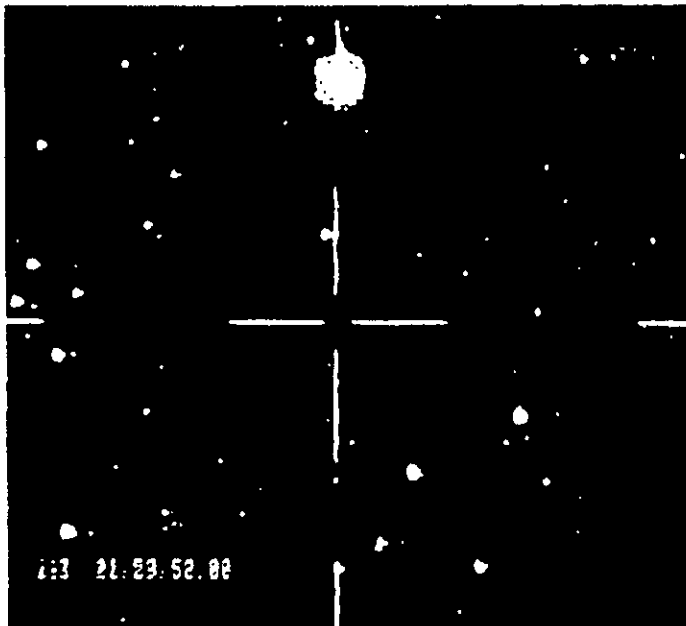

T = 1 SEC

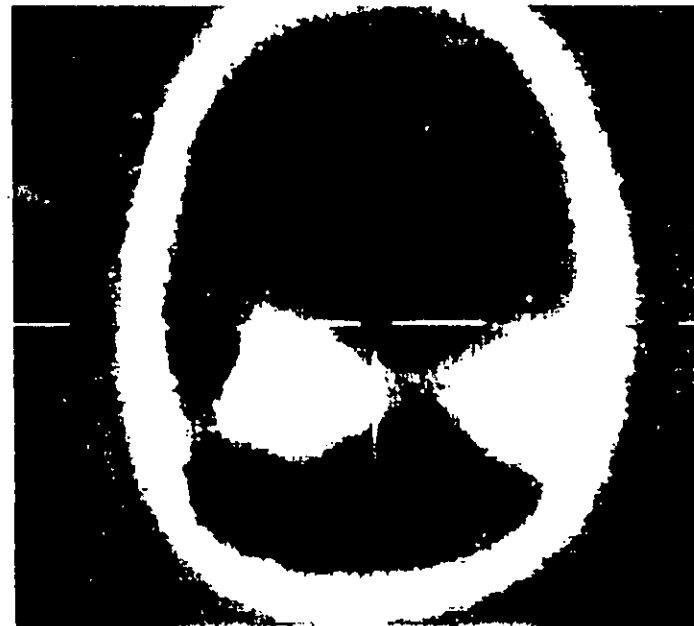

T = 10 SEC

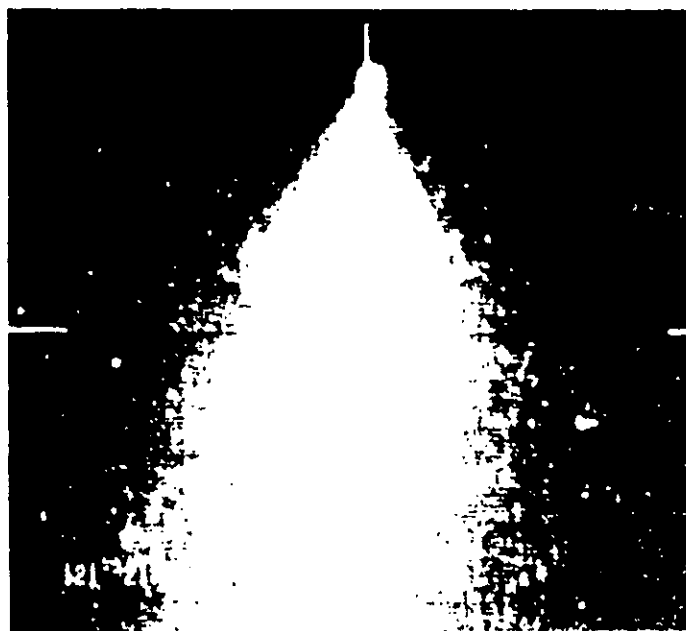

T = 20 SEC

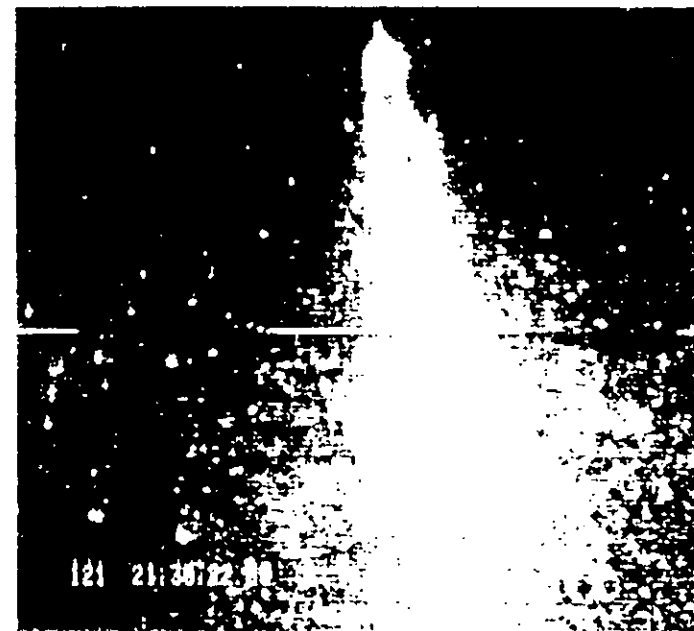



# IBSS NEAR FIELD OMS PLUME DATA

T = 0 SEC

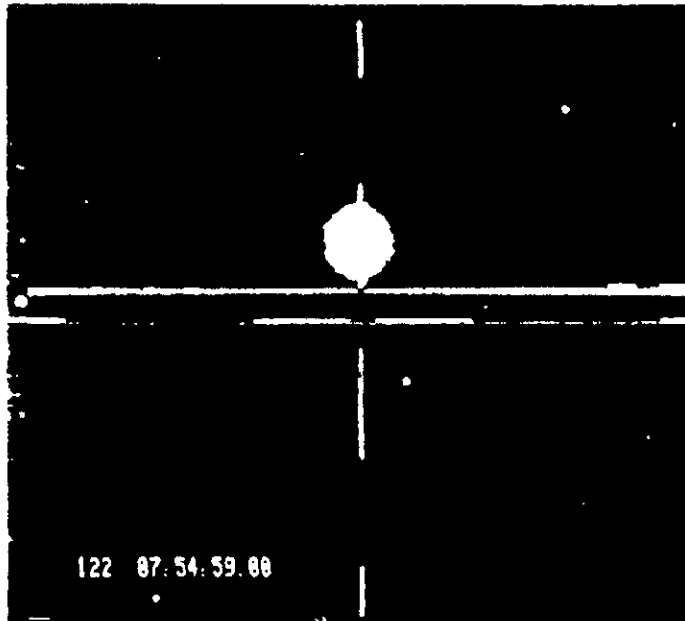

T = 1 SEC

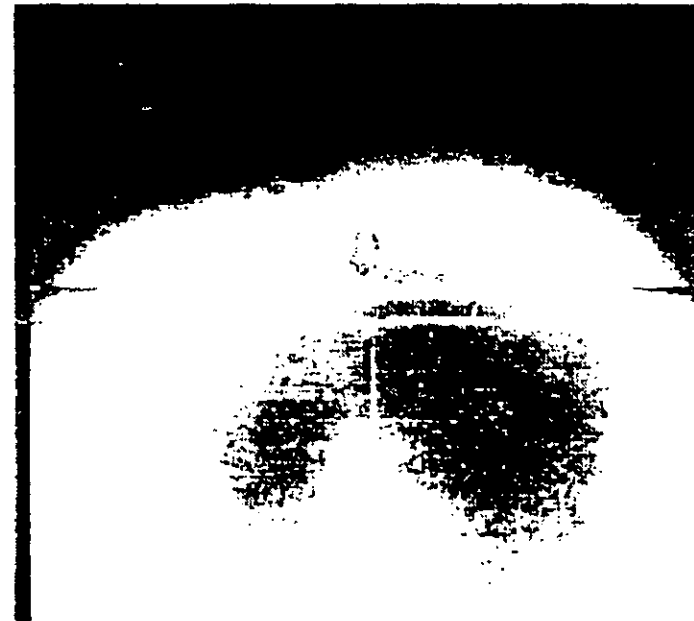

T = 10 SEC



T = 20 SEC

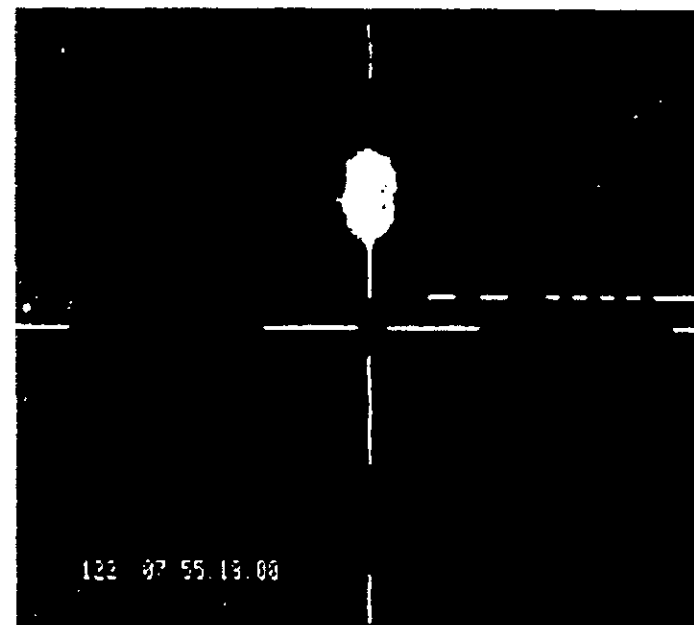

910 1261 1  
21 Oct 01



UNCLASSIFIED

# MOTIVATION FOR THE IBSS CHEMICAL RELEASE OBSERVATIONS

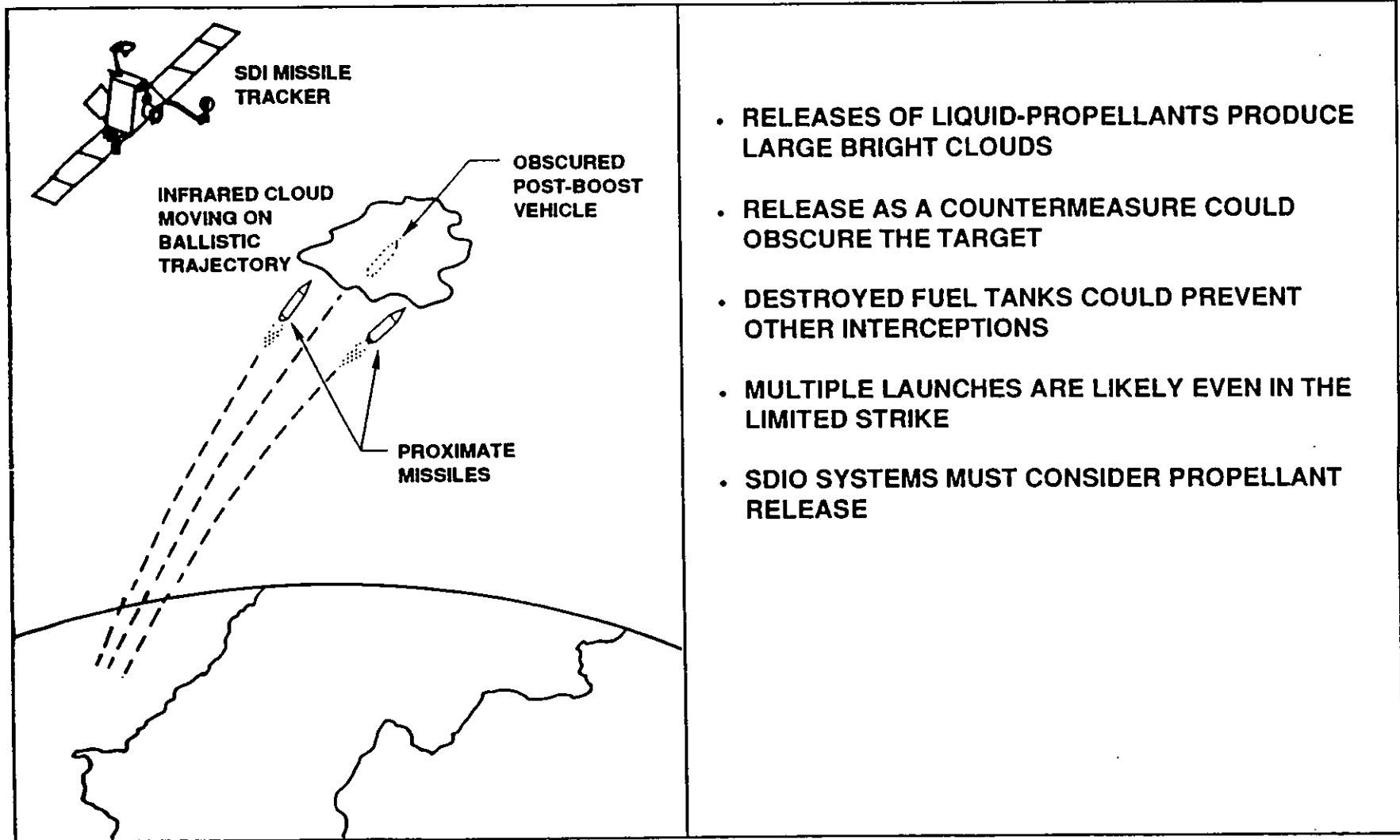

UNCLASSIFIED

91U-1076/2  
21 Oct 91



UNCLASSIFIED

# CHEMICAL RELEASE OBSERVATION

OBJECTIVE: CLOUD CHARACTERIZATION

RESULTS: ALL EXPERIMENTS SUCCESSFUL

- SUPPORTING DATA
- SDIO HALO AIRCRAFT
- GROUND OBSERVATION

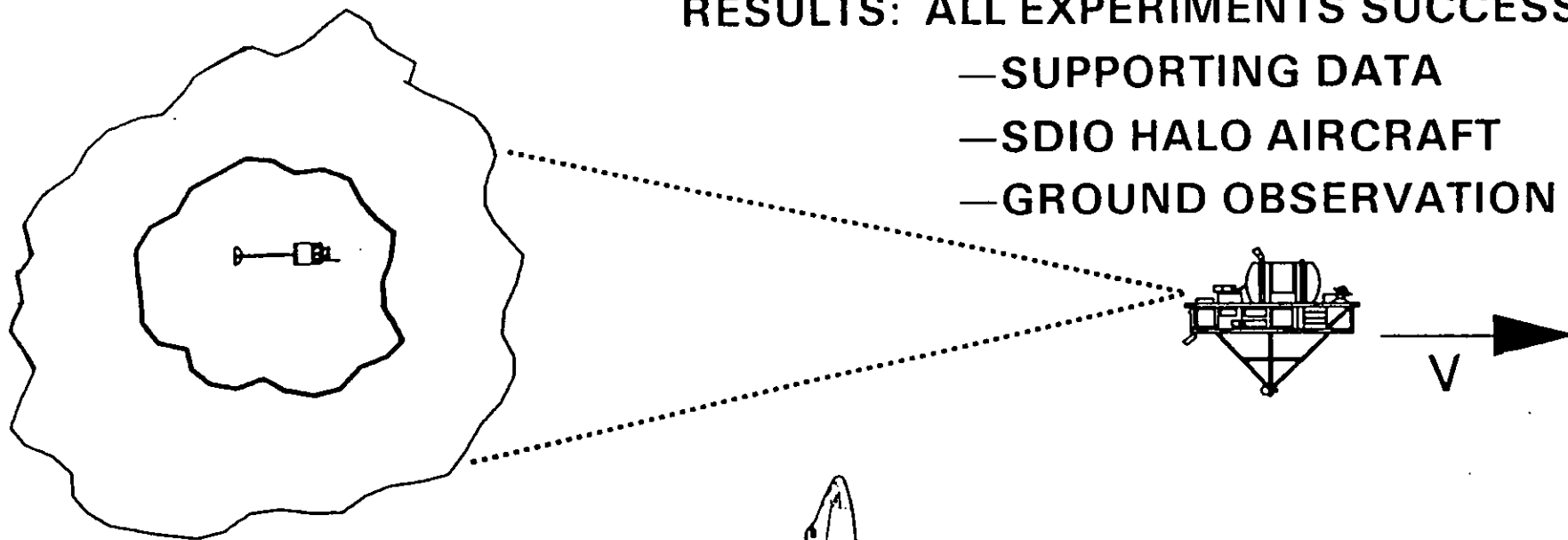

CRO/A (MMH)	72 MILES
CRO/B (UDMH)	50 MILES
CRO/C (N <sub>2</sub> O <sub>4</sub> )	109 MILES

UNCLASSIFIED



UNCLASSIFIED



# EARTH BACKGROUNDS

**OBJECTIVES:**

TO COLLECT DATA ON THE HARD EARTH, EARTH LIMB, AND AURORA

**RESULTS:**

ALL PLANNED MEASUREMENTS COMPLETED



UNCLASSIFIED

91U-1251  
15 OCT 91



UNCLASSIFIED

# CIV MEASUREMENT

OBJECTIVE:  
INVESTIGATE GAS IONIZATION

RESULTS:  
ALL RELEASES COMPLETED

ORBITER

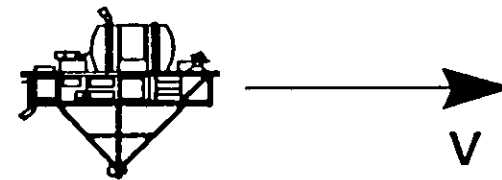
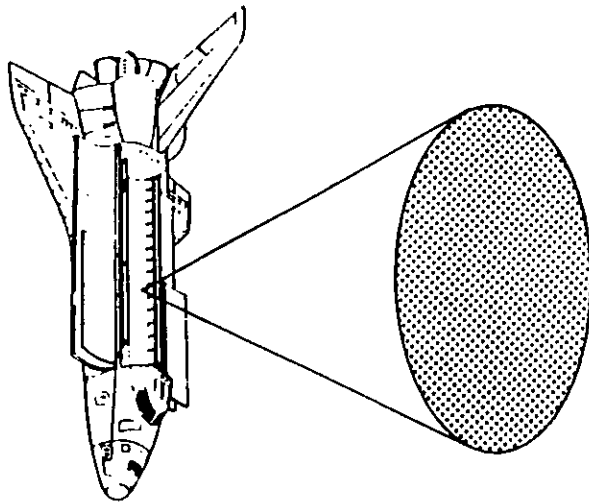

SPAS

UNCLASSIFIED

91U-1253  
15 OCT 91



# CIV RELEASE #1

T = 0 SEC

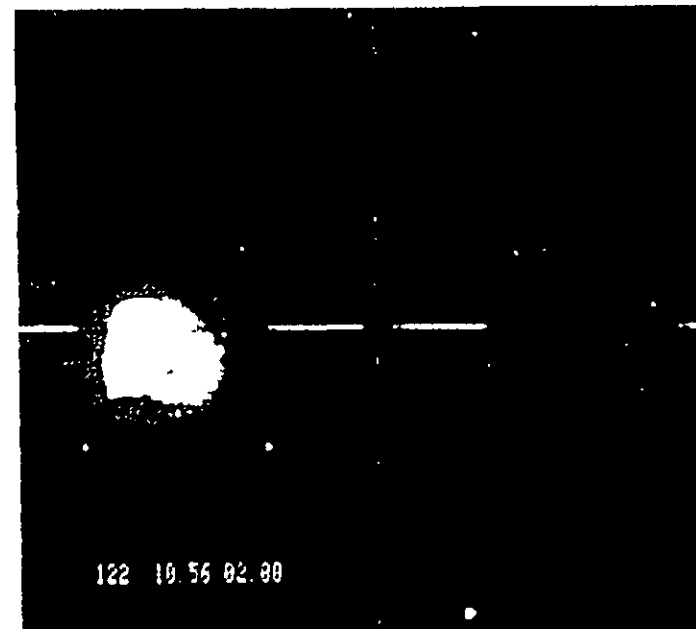
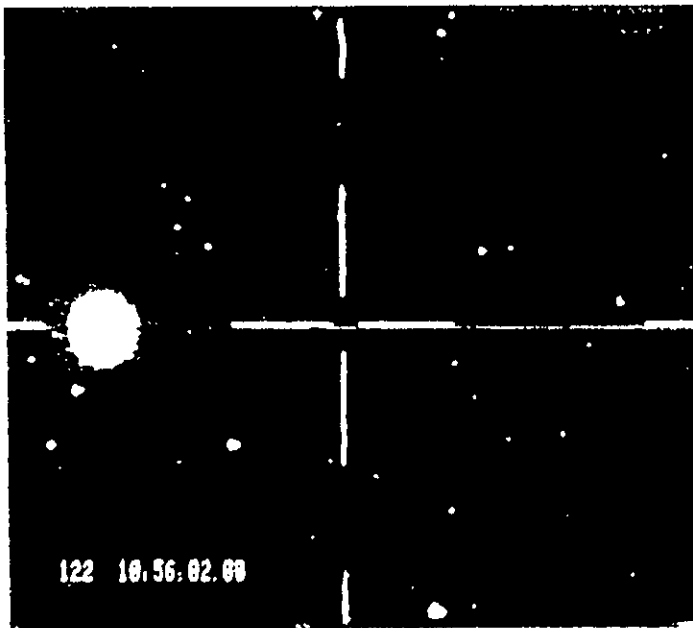

T = 0.2 SEC

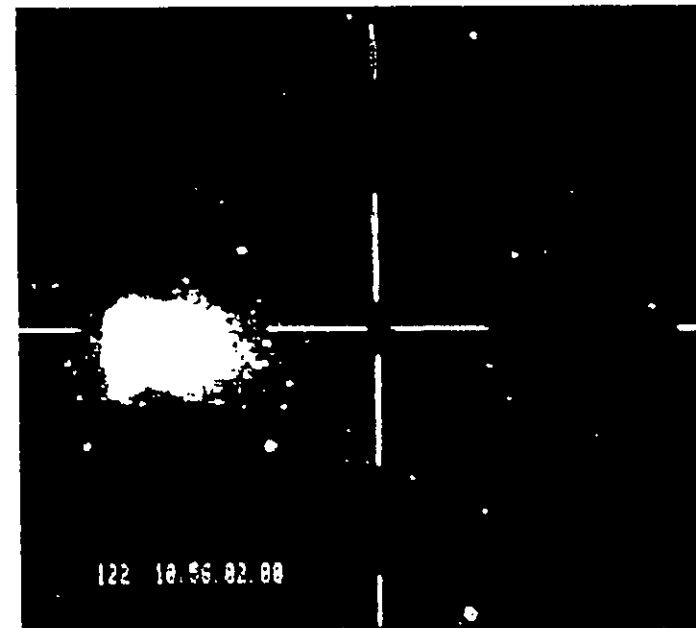
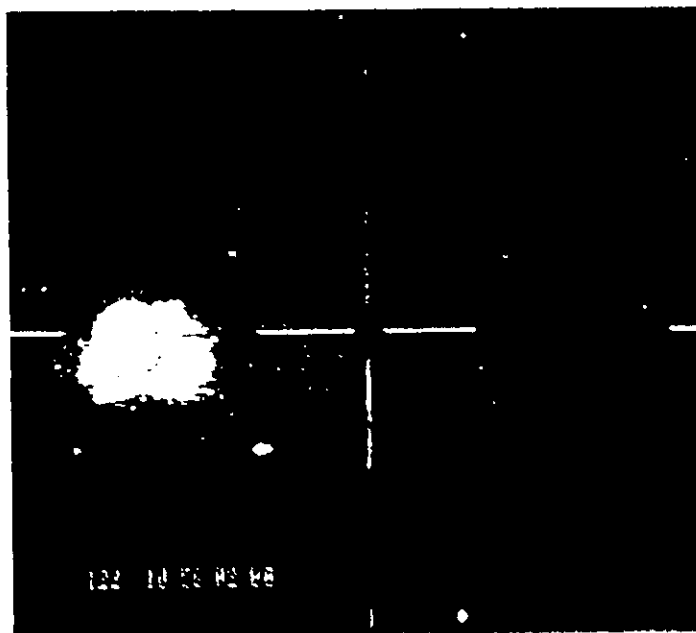

T = 0.3 SEC

2010510  
2010510



UNCLASSIFIED

# ORBITER ENVIRONMENT MEASUREMENT

## OBJECTIVES:

MEASURE SHUTTLE  
GLOW AND  
CONTAMINATION  
ENVELOPE

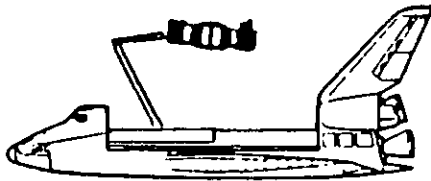

SPAS ON THE REMOTE  
MANIPULATOR SYSTEM (RMS)

## OPERATIONAL RESULTS:

ALL PLANNED  
MEASUREMENTS  
COMPLETE

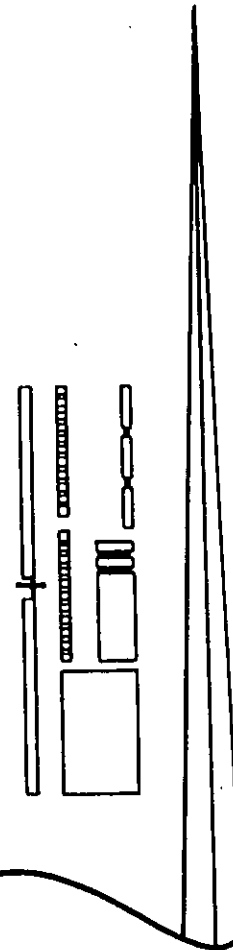

SPAS VIEW OF ORBITER TAIL

UNCLASSIFIED

91U-1255/1  
21 Oct 91



UNCLASSIFIED

# ORBITER TAIL GLOW AFTER THRUSTER FIRING



SHUTTLE GLOW UNDER PASSIVE CONDITIONS



SHUTTLE GLOW AFTER THRUSTER FIRING

WIDE ANGLE IR

UNCLASSIFIED



# ON-ORBIT PERFORMANCE VERIFICATION

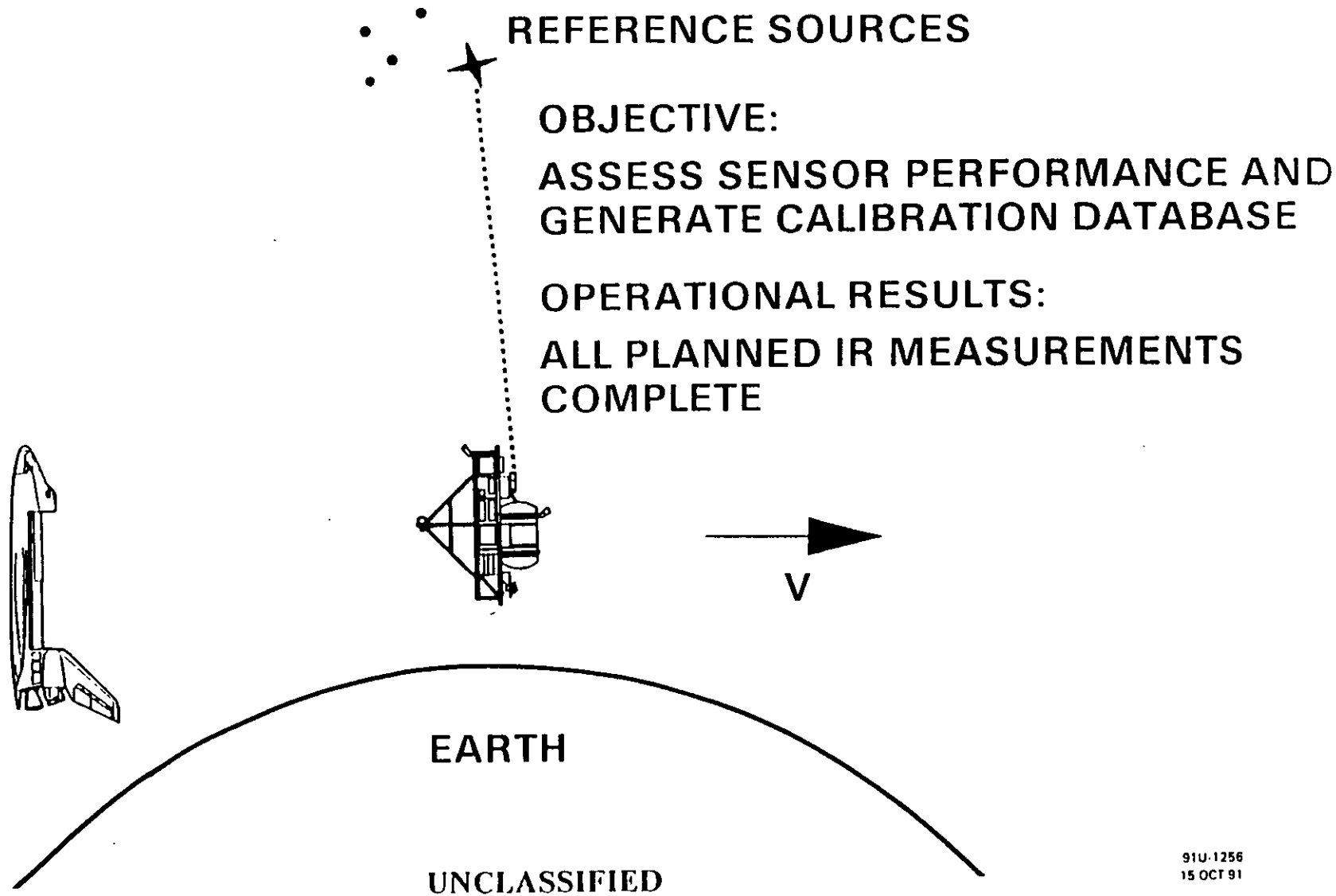



UNCLASSIFIED

# OPERATIONS

---

- CREW PERFORMANCE—OUTSTANDING
- VERY SUCCESSFUL, HIGH RATE NUMBER OF EXPERIMENTS
- EXPERIMENT POINTING VERY EFFECTIVE
- RMS TV VERIFICATION OF AIS POSITION
- EXECUTED LARGE NUMBER OF COMMANDS FLAWLESSLY
- ORBITER PERFORMANCE
  - DISCOVERY EXCEEDED PERFORMANCE

**ORBITER AND MAN IN LOOP VERY EFFECTIVE/VALUABLE**

UNCLASSIFIED

91U-05517  
14 JUN 91



UNCLASSIFIED

# IBSS DATA COLLECTION SUMMARY

---

<u>EXPERIMENT</u>	<u>COMPLETED</u>	<u>PLANNED</u>
PRIMARY		
CATEGORY 1 (REQUIRED)	15	15
CATEGORY 2 (DESIRED)	15	15
SUPPLEMENTAL		
CATEGORIES 3-5	19	23
UNPLANNED	5	—
CALIBRATIONS	18	—

UNCLASSIFIED





UNCLASSIFIED

## VALUE TO SDIO

---

- REAL PLUME TARGET SIGNATURES FOR SYSTEM DESIGN
- DATA FOR FIRST VALIDATED UV PLUME MODEL
- MISSILE PROPELLANT COUNTERMEASURE EVALUATION
- IMPACT ASSESSMENT OF KEY PHENOMENA ON SYSTEM DESIGNS
- ENHANCED EARTH BACKGROUND DATA AND DIAGNOSTIC DATA FOR MODELERS
- PROVEN LOW COST SPACE DATA COLLECTION PLATFORM

UNCLASSIFIED

91U-0553  
10 JUN 91

UNCLASSIFIED



## **IBSS UNIQUENESS**

---

- **FIRST AND ONLY SDIO INTERNALLY MANAGED SPACE PROGRAM**
- **ONLY MAJOR SPACE EXPERIMENT FOR SDI WITH ALLIED COUNTRIES**
- **DEMONSTRATED UTILITY/EFFECTIVENESS OF USING SHUTTLE**
- **REUSABLE SDIO SPACECRAFT ASSET**
- **CONTROLLED PROGRAM COST**

UNCLASSIFIED

01U-0554  
10 JUN 01

# NASA

## SPACE SHUTTLE MISSION STS-39

### PRESS KIT



MARCH 1991

## **PUBLIC AFFAIRS CONTACTS**

### **NASA**

Mark Hess/Jim Cast/Ed Campion  
Office of Space Flight  
NASA Headquarters, Washington, D.C.  
(Phone: 202/453-8536)

Lisa Malone  
Kennedy Space Center, Fla.  
(Phone: 407/867-2468)

Jerry Berg  
Marshall Space Flight Center, Huntsville, Ala.  
(Phone: 205/544-0034)

James Hartsfield  
Johnson Space Center, Houston, Texas  
(Phone: 713/483-5111)

Delores Beasley  
Goddard Space Flight Center, Greenbelt, Md.  
(Phone: 301/286-2806)

Myron Webb  
Stennis Space Center, Miss.  
(Phone: 601/688-3341)

Nancy Lovato  
Ames-Dryden Flight Research Facility, Edwards, Calif.  
(Phone: 805/258-3448)

## **PUBLIC AFFAIRS CONTACTS**

### **DOD**

**Capt. Marty Hauser**  
Secretary of the Air Force Public Affairs  
The Pentagon  
(Phone: 703/695-5766)

**Betty Ciotti**  
USAF Space Systems Division  
Los Angeles AFB, Calif.  
(Phone: 213/363-6836)

**Maj. Carolyn Channave**  
DOD/SDIO External Affairs  
The Pentagon  
(Phone: 703/693-1777)

**Robert McKinney**  
SDIO External Affairs  
The Pentagon  
(Phone: 703/693-1778)

**Lt. Col. Jim Jannette**  
Eastern Space and Missile Center, Fla.  
(Phone: 407/494-7731)

## CONTENTS

GENERAL INFORMATION.....	5
GENERAL RELEASE.....	6
STS-39 QUICK LOOK.....	9
SUMMARY OF MAJOR ACTIVITIES.....	10
SPACE SHUTTLE ABORT MODES.....	12
TRAJECTORY SEQUENCE OF EVENTS.....	13
VEHICLE AND PAYLOAD WEIGHTS.....	14
STS-39 PRELAUNCH PROCESSING.....	15
SHUTTLE ADVANCED GENERAL PURPOSE COMPUTER.....	16
STS-39 MISSION OVERVIEW.....	17
AIR FORCE PAYLOAD-675 (AFP-675).....	20
CIRRIS-1A.....	20
AURORA DETAILS.....	23
FAR UV.....	24
URA.....	25
HUP.....	26
QINMS.....	28
INFRARED BACKGROUND SIGNATURE SURVEY (IBSS).....	29
IBSS OVERVIEW.....	29
SPAS-II.....	29
CRO.....	29
CIV.....	33
IBSS OBJECTIVES.....	35
IBSS PLUME OBSERVATIONS.....	37
EARTH BACKGROUND EXPERIMENTS.....	37
ORBITER ENVIRONMENT EXPERIMENT.....	38
IBSS PARTICIPANTS.....	39
STS-39 SPAS/IBSS RENDEZVOUS & TRACKING OPERATIONS.....	40
SECONDARY PAYLOADS:	
STP-1.....	44
OVERVIEW.....	44
HITCHHIKER PROJECT.....	44
ULTRAVIOLET LIMB IMAGING (UVLIM) EXPERIMENT.....	46
ADVANCED LIQUID FEED EXPERIMENT (ALFE).....	46
SPACECRAFT KINETIC INFRARED TEST (SKIRT).....	48
ASCENT PARTICLE MONITOR (APM).....	49
DATA SYSTEM EXPERIMENT (DSE).....	50

STP-1 PARTICIPANTS.....	51
MULTI-PURPOSE EXPERIMENT CANISTER (MPEC).....	52
CLOUDS 1A.....	52
RADIATION MONITORING EQUIPMENT-III .....	53
STS-39 CREW BIOGRAPHIES.....	54
SPACE SHUTTLE MANAGEMENT .....	58
UPCOMING SPACE SHUTTLE MISSIONS.....	62
PREVIOUS SPACE SHUTTLE FLIGHTS.....	63

## **GENERAL INFORMATION**

### **NASA Select Television Transmission**

NASA Select television is available on Satcom F-2R, Transponder 13, located at 72 degrees west longitude; frequency 3960.0 MHz, audio 6.8 MHz.

The schedule for television transmissions from the orbiter and for the change-of-shift briefings from Johnson Space Center, Houston, will be available during the mission at Kennedy Space Center, Fla.; Marshall Space Flight Center, Huntsville, Ala.; Johnson Space Center; and NASA Headquarters, Washington, D.C. The TV schedule will be updated daily to reflect changes dictated by mission operations.

Television schedules also may be obtained by calling COMSTOR, 713/483-5817. COMSTOR is a computer data base service requiring the use of a telephone modem. A voice update of the TV schedule may be obtained by dialing 202/755-1788. This service is updated daily at noon EST.

### **Status Reports**

Status reports on countdown and mission progress, on-orbit activities and landing operations will be produced by the appropriate NASA news center.

### **Briefings**

An STS-39 mission press briefing schedule will be issued prior to launch. During the mission, flight control personnel will be on 8-hour shifts. Change-of-shift briefings by the off-going flight director will occur at approximately 8-hour intervals.



RELEASE: 91-25

## **STRATEGIC DEFENSE SYSTEM TESTS HIGHLIGHT STS-39 MISSION**

Mission STS-39 is the first unclassified Department of Defense-dedicated Space Shuttle mission, highlighted by around-the-clock observations of the atmosphere, gas releases, Shuttle engine firings, subsatellite gas releases and the Shuttle's orbital environment in wavelengths ranging from infrared to the far ultraviolet.

Carried aboard Discovery on its 12th flight, the 39th Shuttle mission, will be Air Force Program-675 (AFP-675); the Infrared Background Signature Survey (IBSS) mounted on the Shuttle Pallet Satellite-II (SPAS-II); the Critical Ionization Velocity (CIV) experiment; three Chemical Release Observation (CRO) subsatellites; the Space Test Payload (STP-1) and a classified payload in a Multi-Purpose Experiment Canister (MPEC).

Inside Discovery's crew cabin will be the Cloud Logic to Optimize the Use of Defense Systems-1A (CLOUDS-1A) experiment and the Radiation Monitoring Equipment-III (RME-III).

Work with these payloads during the flight will involve extensive maneuvering, rendezvous and close proximity operations by Discovery. STS-39 is currently working toward a 3:49 a.m. EST launch on March 9, 1991. Landing is set for Edwards Air Force Base, Calif., at 11:14 a.m. EST on March 17, giving the flight a planned length of 8 days, 7 hours and 26 minutes.

- more -

AFP-675 is a collection of scientific instruments to observe targets such as the atmosphere, the aurora and stars in infrared, far ultraviolet, ultraviolet and X-ray wavelengths. AFP-675 instruments also will analyze the spectrum of various targets and gases released from or around the Shuttle. AFP-675 is sponsored by the U.S. Air Force's Space Systems Division and may provide a better understanding of the difficulties in identifying spacecraft with remote sensors and distinguishing those spacecraft from naturally occurring phenomena. The AFP-675 instruments also are to study several astronomical targets of interest.

~~The Strategic Defense Initiative Organization's IBSS experiment~~ mounted on the SPAS-II platform, will be deployed and retrieved by Discovery so that SPAS-II can observe the Shuttle's engine firings from afar. IBSS will observe and record the infrared signature of these firings and also will perform infrared observations of other targets, including three CRO subsatellites to be released from Discovery. IBSS will observe common rocket fuels nitrogen tetroxide, monomethyl hydrazine and dimethyl hydrazine released from the three CRO subsatellites after they are deployed by Discovery.

IBSS also will observe releases of the gases xenon, neon, carbon dioxide and nitric oxide from canisters in Discovery's payload bay. These gases are part of the CIV experiment, which, with instruments in the payload bay, will observe the releases simultaneously with IBSS. IBSS is sponsored by SDIO and information from its studies may assist in developing remote sensors that can identify missiles.

The STP-1 experiment is a varied collection of scientific instruments, including one that will observe the luminous "airglow" effect of atomic oxygen on Discovery; one that will test a new method of flowing rocket propellants in weightlessness to assist in the design of future engines; and another to observe the fringes of Earth's atmosphere at various times, including sunrise and sunset, in ultraviolet wavelengths. STP-1 is sponsored by the Air Force's Space Systems Division.

Inside the crew cabin, the CLOUDS-1A experiment is a camera the crew will use to photograph various cloud formations on the Earth to better understand cloud movements and structures. The RME-III experiment is designed to monitor radiation levels inside the cabin during the flight.

- more -

Commanding Discovery will be Navy Capt. Michael L. Coats. Air Force Major L. Blaine Hammond will serve as pilot. Mission specialists include Gregory J. Harbaugh; USAF Lt. Col. Don McMonagle; USAF Col. Guion Bluford; C. Lacy Veach; and Richard J. Hieb.

The flight crew will operate in two teams to accommodate 24-hour a day observations aboard Discovery, with each team working a 12-hour shift. On the Red Team will be Hammond, Veach and Hieb. On the Blue Team will be Harbaugh, McMonagle and Bluford. Coats will keep his own hours, independent of any assigned shift.

(End of general release. Background information follows.)

## **STS-39 QUICK LOOK**

### **Launch Date and Site:**

Mar. 9, 1991  
Kennedy Space Center, Fla., Pad 39-A

**Launch Window:** 3:49 a.m. - 6:51 a.m. EST

**Orbiter:** Discovery (OV-103)

**Orbit:** 140 x 140 nautical miles, 57 degrees inclination

**Landing Date/Time:** Mar. 17, 1991, 11:14 a.m. EST

**Primary Landing Site:** Edwards Air Force Base, Calif.

### **Abort Landing Sites:**

Return to Launch Site - Kennedy Space Center, Fla.  
Transoceanic Abort Landing - Zaragoza and Moron, Spain  
Abort Once Around - Northrup Strip, White Sands, N.M.

### **Crew:**

Michael L. Coats, Commander  
Blaine Hammond, Jr., Pilot  
Gregory L. Harbaugh, Mission Specialist 1  
Donald R. McMonagle, Mission Specialist 2  
Guion S. Bluford, Mission Specialist 3  
C. Lacy Veach, Mission Specialist 4  
Richard J. Hieb, Mission Specialist 5

### **Cargo Bay Payloads:**

IBSS/SPAS-II  
CIV  
CRO  
STP-1  
MPEC

### **Middeck Payloads:**

Cloud Logic to Optimize the Use of Defense Systems (CLOUDS-1A)  
Radiation Monitoring Experiment (RME-III)

## **SUMMARY OF MAJOR ACTIVITIES**

### **FLIGHT DAY ONE**

Ascent  
OMS 2  
IBSS on-orbit checkout  
AFP-675 activation  
RME-III activation  
DSO

### **FLIGHT DAY TWO**

AFP-675 operations  
SPAS pre-deploy checkout  
IBSS/SPAS-II unberth; deploy  
IBSS/SPAS-II far-field observations

### **FLIGHT DAY THREE**

IBSS/SPAS-II far-field observations  
IBSS/SPAS-II near-field observations  
CRO-C deploy

### **FLIGHT DAY FOUR**

IBSS/SPAS-II near-field observations  
IBSS/SPAS-II rendezvous  
CRO-B deploy  
IBSS/SPAS-II retrieval; berthing  
DSO

### **FLIGHT DAY FIVE**

AFP-675 operations  
CRO-A deploy

### **FLIGHT DAY SIX**

SPAS-II pre-deploy checkout  
IBSS/SPAS-II unberthing; RMS operations

### **FLIGHT DAY SEVEN**

IBSS/SPAS-II berthing  
AFP-675 operations

FLIGHT DAY EIGHT

AFP-675 operations

STP-I operations

Flight Control Systems checkout

MPEC deploy

Payload deactivation

Cabin stow

FLIGHT DAY NINE

RME-III deactivation; stow

Deorbit; landing

## SPACE SHUTTLE ABORT MODES

Space Shuttle launch abort philosophy aims toward safe and intact recovery of the flight crew, orbiter and its payload. Abort modes include:

- \* **Abort-To-Orbit (ATO)** -- Partial loss of main engine thrust late enough to permit reaching a minimal 105-nautical mile orbit with orbital maneuvering system engines.
- \* **Abort-Once-Around (AOA)** -- Earlier main engine shutdown with the capability to allow one orbit around before landing at either Edwards Air Force Base, Calif.; White Sands Space Harbor (Northrup Strip), NM; or the Shuttle Landing Facility (SLF) at Kennedy Space Center, FL.
- \* **Trans-Atlantic Abort Landing (TAL)** -- Loss of two main engines midway through powered flight would force a landing at either Zaragoza or Moron, Spain.
- \* **Return-To-Launch-Site (RTL)** -- Early shutdown of one or more engines, and without enough energy to reach Zaragoza, would result in a pitch around and thrust back toward KSC until within gliding distance of the SLF.

STS-39 contingency landing sites are Edwards AFB, White Sands, Kennedy Space Center, Zaragoza and Moron.

# TRAJECTORY SEQUENCE OF EVENTS

EVENT	MET (d:h:m:s)	RELATIVE VELOCITY (fps)	MACH	ALTITUDE (ft)
Launch	00/00:00:00			
Begin Roll Maneuver	00/00:00:09	160	.14	600
End Roll Maneuver	00/00:00:19	410	.37	3,500
Throttle Down to 70%	00/00:00:28	630	.56	7,170
Throttle Up to 104%	00/00:00:58	1,320	1.28	33,230
Max. Dynamic Pressure	00/00:01:03	1,460	1.45	38,540
SRB Staging	00/00:02:06	4,190	3.8	154,810
Main Engine Cutoff	00/00:08:30	24,900	21.94	375,830
Zero Thrust	00/00:08:40	24,974	21.68	375,830
ET Separation	00/00:08:50			
OMS 2 Burn	00/00:38:00			
IBSS/SPAS-II Deploy	01/21:10:00			
IBSS/SPAS-II Retrieval	03/11:18:00			
Deorbit Burn	08/06:31:00			
Landing	08/07:26:00			

Apogee, Perigee at MECO: 136 x 23 nautical miles

Apogee, Perigee post-OMS 2: 140 x 140 nautical miles



## VEHICLE AND PAYLOAD WEIGHTS

	<u>Pounds</u>
Orbiter (Discovery) empty, and 3 SSMEs	172,517
Remote Manipulator System (payload bay)	1,258
IBSS/SPAS-II (payload bay)	4,197
AFP-675 (payload bay)	203
Chemical Release Observation (CRO) (payload bay)	1,307
Critical Ionization Velocity (CIV) (payload bay)	1,215
Space Test Program (STP-I) (payload bay)	4,288
Radiation Monitoring Experiment-III (RME-III)	8
Cloud Logic to Optimize the Use of Defense Systems (CLOUDS)	8
Total Vehicle at SRB Ignition	4,512,245
Orbiter Landing Weight	211,300

## **STS-39 PRELAUNCH PROCESSING**

Kennedy Space Center workers began preparing Discovery for its 12th flight into space when the vehicle was towed into the Orbiter Processing Facility on Oct. 18 following its previous mission, STS-33.

Discovery spent about 15 weeks in the processing facility undergoing about 22 modifications and routine testing. One of the significant changes made was the installation of the five new general purpose computers.

Space Shuttle main engine locations for this flight are as follows: engine 2026 in the No. 1 position, engine 2030 in the No. 2 position, and engine 2029 in the No. 3 position.

Booster stacking operations on mobile launcher platform 2 began Nov. 7 and were completed Dec. 13. The external tank was mated to the boosters Dec. 18 and the Orbiter Discovery was bolted to the tank on Jan. 30.

STS-39 primary payloads were installed in Discovery's payload bay in the OPF and at the launch pad. Payloads installed in the OPF include the Critical Ionization Velocity payload and the Chemical Release Observatory. The U.S. Air Force payload 675 and the Shuttle Pallet Satellite-II were installed at the launch pad Feb. 5. The vehicle was rolled out to Launch Pad 39-A on Feb. 4. A dress rehearsal launch countdown was held Feb. 7-8 at KSC.

The launch countdown will begin about 3 days prior to the launch. During the countdown, the orbiter's onboard fuel and oxidizer storage tanks will be loaded and all orbiter systems will be prepared for flight. About 9 hours before launch, the external tank will be filled with its flight load of a half a million gallons of liquid oxygen and liquid hydrogen propellants. About 2 1/2 hours before liftoff, the flight crew will begin taking their assigned seats in the crew cabin.

KSC's recovery teams will prepare the orbiter Discovery for the return trip to Florida following the end-of-mission landing at Edwards AFB, Calif. Orbiter turnaround operations at Dryden Flight Research Facility typically take about 5 days.

## SHUTTLE ADVANCED GENERAL PURPOSE COMPUTER

On STS-39, Discovery's avionics system will feature the first set of five upgraded general purpose computers (GPCs), plus a spare, to fly aboard the Shuttle.

The updated computers have more than twice the memory and three times the processing speed of their predecessors. Officially designated the IBM AP-101S, built by IBM, Inc., they are half the size, about half the weight and require less electricity than the first-generation GPCs. The central processor unit and input/output processor, previously installed as two separate boxes, are now a single unit.

The new GPCs use the existing Shuttle software with only subtle changes. However, the increases in memory and processing speed allow for future innovations in the Shuttle's data processing system.

Although there is no real difference in the way the crew will operate with the new computers, the upgrade increases the reliability and efficiency in commanding the Shuttle systems. The predicted "mean time between failures" (MTBF) for the advanced GPCs is 6,000 hours. The MTBF for the original GPCs is 5,200 hours.

### Specifications

Dimensions:	19.55" x 7.62" x 10.2"
Weight:	64 lbs
Memory capacity:	262,000 words (32-bits each)
Processing rate:	1 million instructions per second
Power requirements:	550 watts

## **STS-39 MISSION OVERVIEW**

The STS-39 mission is comprised of two primary payloads: Air Force Program 675 (AFP-675) and the Strategic Defense Initiative's (SDIO) Infrared Background Signature Survey (IBSS).

There also are two secondary payloads; Space Test Payload (STP-1) and a Multi-Purpose Experiment Canister (MPEC). Two mid-deck experiments, CLOUDS-1A and RME III, are included on the STS-39 mission. IBSS and AFP-675 have scheduled observing time throughout the mission with a small amount of dedicated time for both STP-1 and MPEC on the last day of the mission.

The AFP-675 payload is sponsored by SDIO and Air Force Systems Command's Space Systems Division (SSD). It contains three experiments sponsored by the Phillips Laboratory's Geophysics Directorate, by the Naval Research Laboratory, and by the Los Alamos National Laboratory, respectively. The prime integration contractor for the payload is Lockheed Missiles and Space Company, Inc. AFP-675 is a unique demonstration of the ability to command, control and evaluate a system of experiments without ground commands or telemetry data. Voice (although not necessary) will be included on this mission for communication between the crew and the ground to discuss the experiments.

The AFP-675 payload will remain in the payload bay during the mission, and commanding of the experiments will be accomplished by the crew from a panel in the aft flight deck. The experiments will be measuring infrared, ultraviolet, visible and X-ray emissions. One of the important observations for the mission is the aurora. The launch date and time were chosen to assure visibility of the aurora.

SDIO's IBSS payload is composed of three separate systems, the Shuttle Pallet Satellite (SPAS-II), the Critical Ionization Velocity (CIV) system and the Chemical Release Observation (CRO) experiment. SDIO has program management responsibility. The SPAS-II was developed by Messerschmitt-Bolkow-Blohm (MBB). The CIV portion is managed by the Geophysics Directorate, and the CRO portion is managed by the Western Space Technology Center. Mission operations are managed by SSD.

# STS-39 CARGO CONFIGURATION

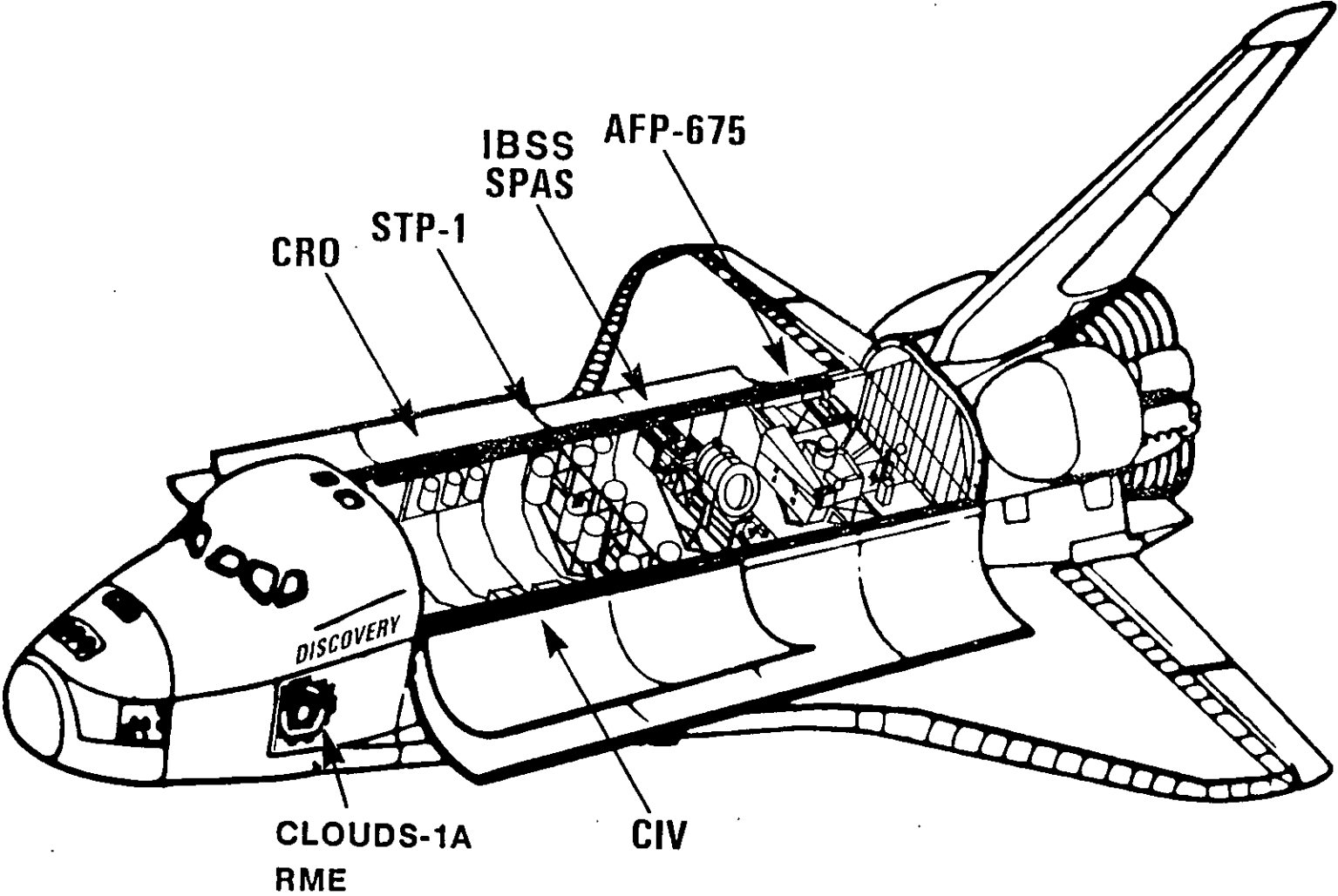

The SPAS-II structure supports a cryogenically cooled infrared sensor, an ultraviolet multispectral sensor and low light level television cameras. The SPAS-II will be deployed and maneuvered to observe various targets and can be commanded by the on-board crew or by the ground.

The CRO is composed of three separate subsatellite structures that will be deployed and will release chemicals upon ground command to be observed by the SPAS infrared sensors. Each subsatellite is loaded with a different chemical. The CIV structure is composed of four separate gas canisters which remain attached to the orbiter and will release gas upon command to be observed by the SPAS sensors. Each cylinder is loaded with a different gas; xenon, neon, carbon dioxide and nitrous oxide.

SSD sponsors the STP-1 payload which is a standard Goddard Space Flight Center (GSFC) Hitchhiker structure supporting five experiments. Experiments are sponsored by the Naval Research Laboratory, the Rocket Propulsion Directorate of the Phillips Laboratory, the Geophysics Directorate, GSFC, and SSD.

STP-1 remains in the cargo bay and is commanded from a control center at Goddard Space Flight Center. The UVLIM experiment will collect airglow measurements, ALFE will evaluate advanced propellant management systems, and SKIRT will collect infrared, visible and ultraviolet data on Shuttle glow. DSE will test advanced data management concepts, and APM will collect particles to study particulate contamination in the Shuttle bay.

MPEC is a multipurpose experiment cannister sponsored by SSD. The MPEC will deploy a classified experiment on the last day of the mission.

There are two mid-deck experiments on the STS-39 mission. The CLOUDS-1A experiment will study cloud cover, and the RME-III experiment will measure ionizing radiation exposure in the orbiter cabin.

## **AIR FORCE PAYLOAD-675**

### **Cryogenic Infrared Radiance Instrumentation for Shuttle (CIRRIS-1A)**

The CIRRIS instrument is sponsored by the Strategic Defense Initiative Organization (SDIO), and program responsibility is under the Phillips Laboratory's Geophysics Directorate at Hanscom Air Force Base, Md. The sensor prime contractor is Utah State University with major subcontractors Space Data Corporation, Sensor System Group and Boston College.

CIRRIS-1A is the highest priority experiment being flown on the AFP-675 space vehicle. The experiment is designed to be operated by Discovery's crew from a command panel in the aft flight deck.

The experiment operates in the infrared portion of the electromagnetic spectrum (wavelength between 2.5 to 25 micro-meters). The experiment will obtain simultaneous spectral and spatial measurements of airglow and auroral emissions.

The data obtained from the mission should help answer questions regarding the optimum atmospheric windows for detecting cold body targets, the background radiance levels in various regions, the spatial structure (clutter) of the background, and the variability of Earth limb emissions during day/night airglow and auroral events. This information will help DOD design surveillance systems.

There is a low light level television co-aligned on the sensor telescope which can be used by the crew to acquire and track the auroral displays and celestial calibration targets.

One primary mission objective is to measure the spectral and spatial characteristics of auroral emissions. The pre-midnight/midnight sector of the Northern and Southern auroral oval is expected to exhibit the most intense infrared emissions and therefore, is of particular interest. An auroral watch will be maintained by a network of ground personnel to monitor the level of auroral activity. In the event of an intense auroral display, this team would alert Discovery's crew of the location and intensity of the aurora.

Earth limb emissions will be collected covering a range of altitudes, latitudes, day/night and geomagnetic conditions.

# AFP-675 SPACE VEHICLE CONFIGURATION

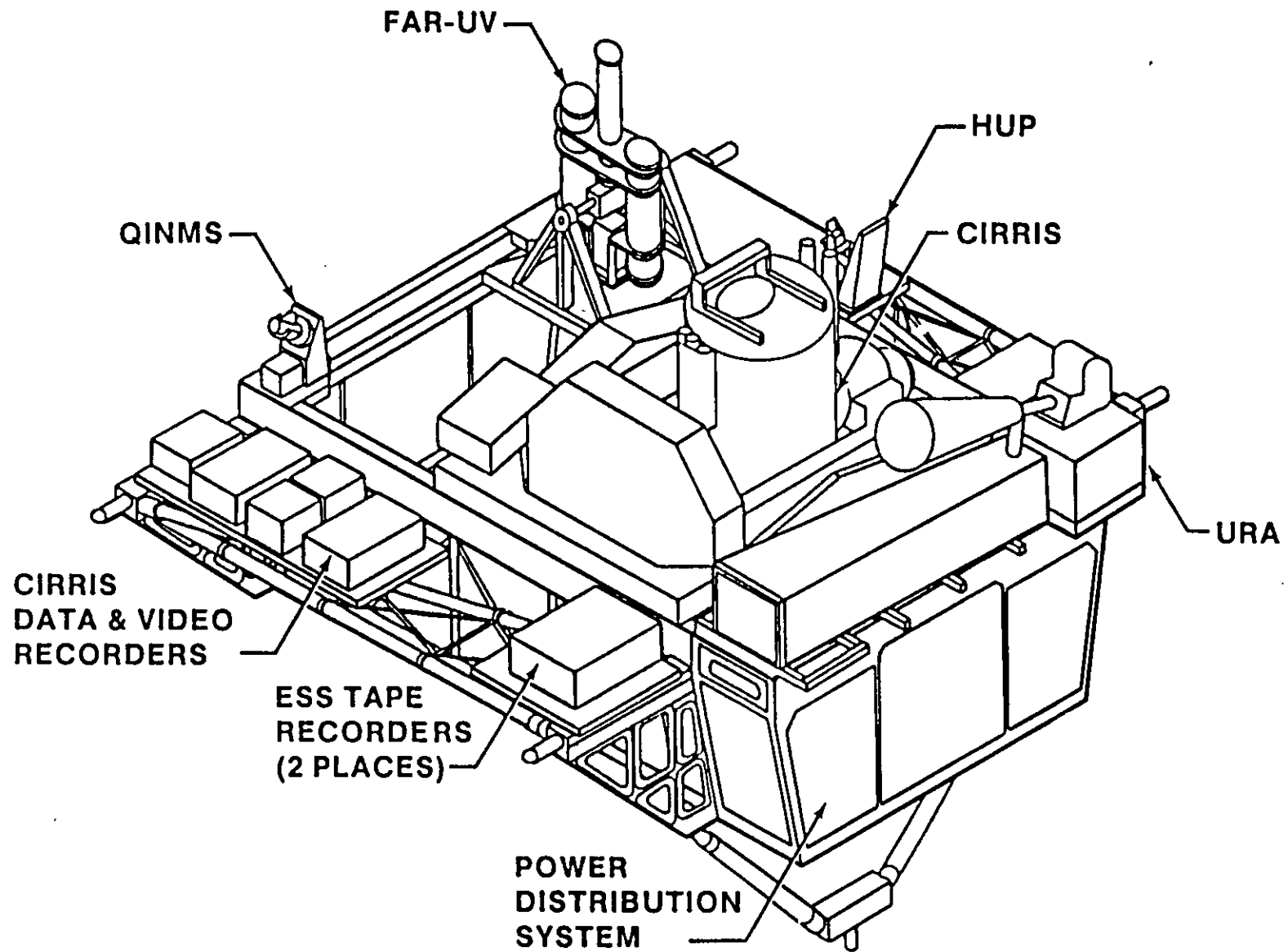



# CIRRIS EXPERIMENT CONFIGURATION

22

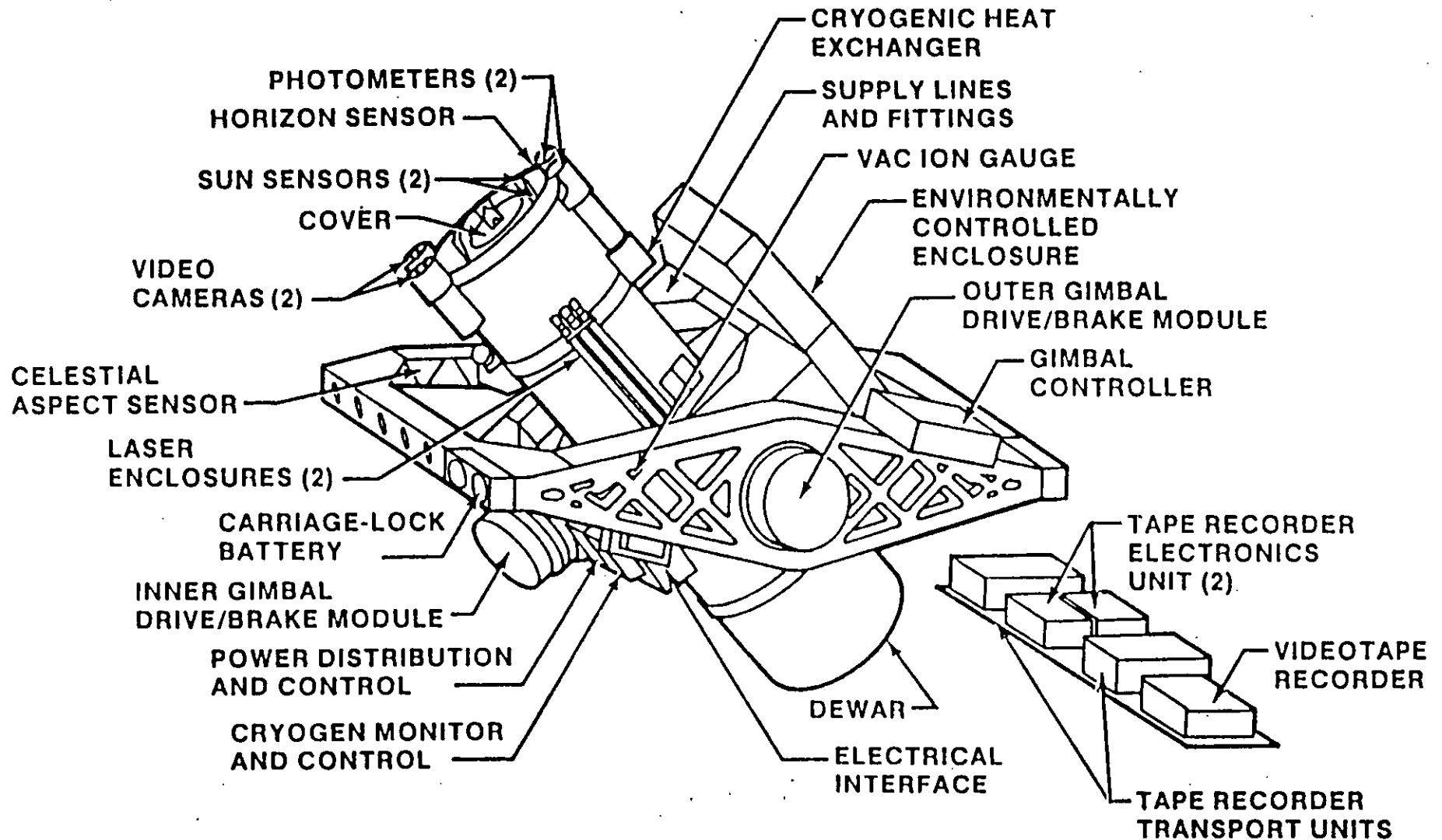

To provide a radiometric calibration of the infrared sensors, certain known celestial sources will be measured during the mission.

Discovery will be maneuvered to provide the proper attitude for observations and to provide the required scanning and pointing capability. The sensor is mounted on a two-axis gimbal.

Gravity gradient is the primary attitude for CIRRI-1A data collection. It is the only attitude maintainable by the orbiter without the use of the reaction control system which produces unacceptable contaminants.

### **Aurora Details**

Aurora are created by solar activity. When a solar flare, sun spot or coronal hole occurs within a particular area of the sun's disk, an increased number of energetic particles is directed towards the Earth. As the solar wind accelerates with the Earth's magnetosphere, a generator effect is produced which accelerates electrons down the Earth's magnetic field lines. As these electrons impinge upon the Earth's atmosphere, oxygen and nitrogen are excited and ionized to produce aurorae. The aurorae emit visible, ultraviolet, infrared and radio frequencies. Because the electrons precipitate down the geomagnetic field lines, aurorae are produced in an oval shaped zone roughly centered around the magnetic pole regions of the North and South poles.

The shape and size of the oval is dependent on the intensity of the solar wind. The intensity of the aurora within the oval is variable. The objective of the mission is to observe an extremely active aurora. The two primary indicators for predicting when an active aurora might appear are solar activity and geomagnetic disturbance. These events will both be monitored during the mission.

A ground station magnetometer network and Defense Meteorological Satellite Program (DMSP) satellite coverage will be utilized to detect whether an active aurora is in progress. This network is located in the Northern Hemisphere and will collect simultaneous scientific measurements as well as provide a near realtime detection capability. The southern aurora is a mirror image of the northern aurora. If there is an active northern aurora then the southern aurora also will be active.

## **FAR Ultraviolet Cameras (FAR UV)**

The FAR Ultraviolet Cameras experiment is sponsored by the Naval Research Laboratory. The hardware is a part of the AFP-675 payload. The instrumentation consists of two electrographic Schmidt cameras. A course-pointing two axis gimbal platform and a low light level TV camera for finding the objects and guiding the instrument. The instrument also has a stabilization system for long exposures on celestial objects. The instrument weighs approximately 550 pounds and the dimensions are approximately 60" x 32" x 20".

The cameras will record naturally-occurring and man-made emission phenomena in near-Earth space in the 1050-1600 angstroms (A) and 1230-2000A wavelength ranges. The phenomena of interest include day and night airglow, diffuse aurorae and the orbiter environment. Of particular interest is the orbiter thruster and surface glow effects.

The experiment also will make observations of interplanetary and interstellar media, stars, extragalactic objects, effects of chemical deposition and atmospheric density measurements by stellar occultation.

Each camera has a film transport loaded with 150 feet of film yielding up to 900 frames of data. The gimballed platform allows pointing of FAR UV to be somewhat independent of orbiter attitude. The outer gimbal can travel between +/- 80 degrees and the inner gimbal can travel between +/- 22 degrees.

The experiment is commanded by a crew member who views the TV monitor to determine where the camera is pointing as he moves the camera into position.

The sun sensor is an array of silicon solar cells which outputs a voltage of 5 volts in full sunlight. As the output from the sun sensor in excess of 3 volts indicates the sun is shining into the payload bay and hence, the FAR UV high voltage must be turned off and the doors closed.

The terrestrial atmospheric observations include northern and southern diffuse aurora, snapshot views of discrete aurora, night airglow with attention to the tropical arcs and twilight airglow. Stellar occultation observations will occur concurrent with airglow observations. Any unique phenomena such as meteor showers should be noted if they occur in airglow or aurora viewing periods.

The celestial target observations include the diffuse nebulae, diffuse galactic background, star fields at high and low galactic latitudes, and also nearby external galaxies.

The primary Shuttle environment events are the primary RCS and OMS thruster firings (in daylight and dark) and Shuttle glow. Secondary interests are Shuttle contamination effects such as fuel cell purges, flash evaporator events and water dumps.

### **Uniformly Redundant Array (URA)**

The URA experiment is sponsored by the Department of Energy and Los Alamos National Laboratory.

The URA is designed to conduct studies of astrophysical sources of X-ray radiation. The instrument, a part of the AFP-675 payload, is an assembly consisting of a detector, a 35mm camera and an electronics package. The aperture plate of the detector contains over 26,000 hexagonal holes to collect the X-ray photons. Objects will be selected to test the capability of the URA to image point sources, complex collections of point sources and extended objects. The instrument will be operated both in a staring and slow scan mode. The URA experiment will be controlled by a mission specialist via the CMP (Command and Monitor Panel).

The URA must not only detect X-rays of interest but must also suppress detection of particles that are present as background. The backgrounds of concern are mainly cosmic rays (relativistic protons and alpha particles) and charged particles (electrons above a 50 keV energy) trapped by the Earth's magnetic field. Because such particles penetrate the detector walls or window, the backgrounds are rejected by anti-coincidence, second moment and rise time discrimination techniques.

The extended charge distribution from an energetic charged particle, as opposed to an X-ray photon, produces a slower amplifier pulse because it is collected over a finite period of time. Rise time discrimination is thus an independent means of background rejection.

Despite the background rejection provisions, URA will not operate usefully at high levels of background. Cosmic ray background is less at low latitude and altitude because of the shielding effect of the Earth's magnetic field. X-ray experiments are not successful in high background regions, which are found at high altitude, and high magnetic latitude, and in the South Atlantic Anomaly. Low altitude, low latitude will increase the success of the URA observations.

### **Horizon Ultraviolet Program (HUP)**

The HUP is an AF Geophysics Laboratory experiment to demonstrate a capability to measure the spatial and spectral characteristics of the Earth's horizon as observed in the ultraviolet wavelength region and to analyze Shuttle contamination.

The instrument weighs less than 40 pounds and is approximately 15" x 21" x 9". The ultraviolet instrument is smaller and does not require cooling like the infrared instruments. The experiment runs continuously during the mission. The line of sight of the instrument is in the -Z direction, vertically out of the Shuttle bay.

The telescope assembly is pivoted about an axis which enables the field of view to vary from local horizontal to a few degrees below the hard Earth horizon. Data will be collected using continuous angle scans at a series of wavelengths in the range of 1100-1900 A, continuous wavelength scans in a fixed direction and a fixed wavelength fixed direction.

To prevent damage from the sun, a solar protection sensor closes the spectrometer shutter when the sun is within 3 degrees of the line of sight. The spectrometer then automatically starts a calibration cycle and resumes data taking when the sun is no longer in the field of view.

The HUP instrument will measure the atmospheric radiance as a function of tangent altitude. The horizon limb profiles are necessary to develop attitude sensors for spacecraft and to obtain backgrounds for above the horizon missile detection techniques. The radiance is due to solar scattering, airglow and auroral excitation. Contamination of the orbiter environment also will be measured.

**CLOUDS 1A CONFIGURATION**

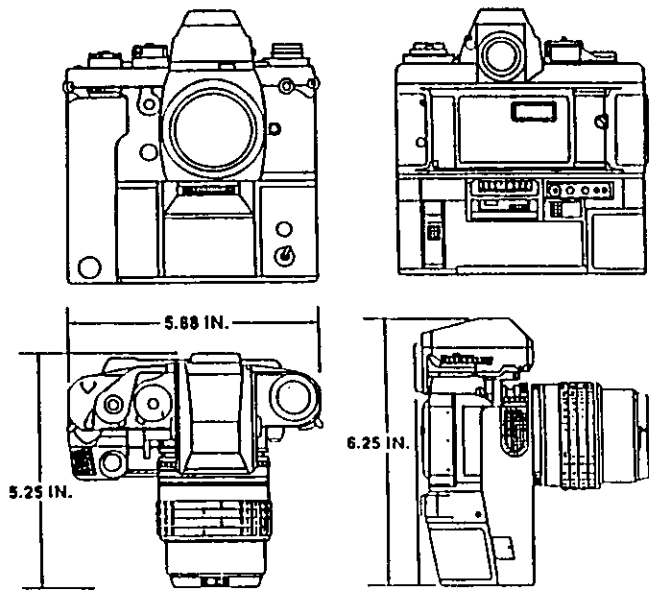

**FAR UV INSTRUMENT**

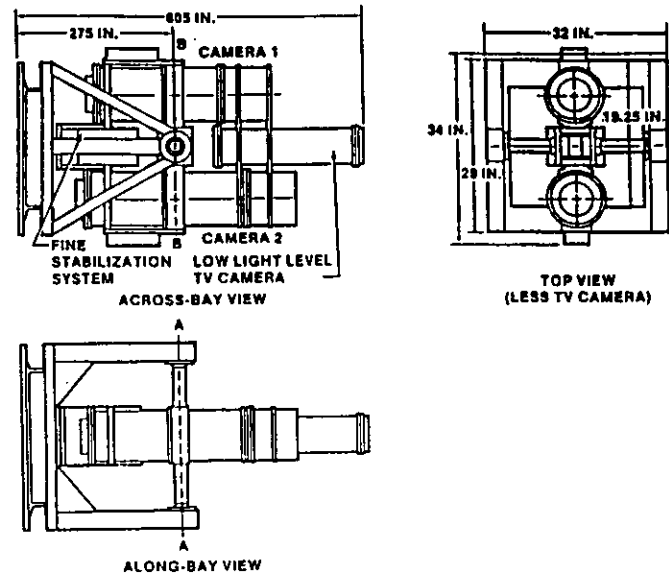

**QINMS EXPERIMENT CONFIGURATION**

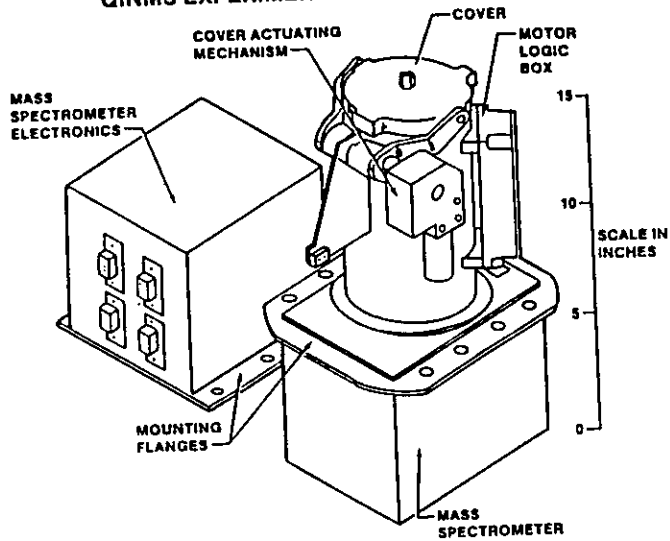

**HUP INSTRUMENT**

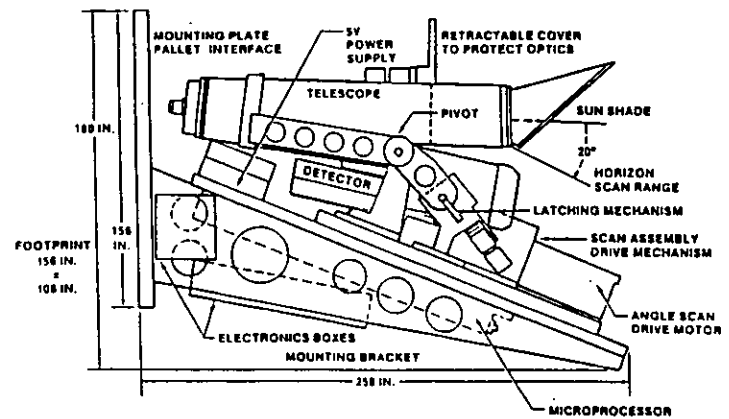

The experiment should yield data radiation backgrounds from the airglow and aurora Earth limb measurements, and information on variability and clutter in the atmosphere.

### **Quadrupole Ion-Neutral Mass Spectrometer (QINMS)**

The QINMS experiment is sponsored by the Phillips Laboratory's Geophysics Directorate. The mass spectrometer instrument weighs approximately 28 pounds. The hardware, part of the AFP-675 payload, is mounted to the ESS and does not gimbal.

The primary role of QINMS is to support CIRRIS by measuring the amount and nature of orbiter bay contamination, particularly water concentration. CIRRIS will not be operated until contamination levels are low.

QINMS will collect data continuously throughout the flight with operations controlled by a Mission Specialist via the CMP.

Data also will be collected while passing through the auroral zone and polar latitude. Levels of hydrogen, oxygen, water vapor and other gases will be measured.

# **INFRARED BACKGROUND SIGNATURE SURVEY (IBSS)**

## **IBSS Overview**

~~Infrared Background Signature Survey is a Strategic Defense Initiative Organization sponsored program for the purpose of obtaining scientific data for use in the development of ballistic missile defense sensor systems~~

IBSS is composed of three separate elements: the Shuttle Pallet Satellite II (SPAS -II), the Critical Ionization Velocity (CIV) package, and the Chemical Release Observation (CRO) experiment. In addition to sponsoring the program, SDIO also manages the overall program. Supporting SDIO in program management are several systems engineering and technical analysis firms, including: Stears, Kiya and Wright of Arlington, Va; Orbital Systems Limited of Lanham, Md; Nichols Research Corp. of Vienna, Va., and Hernandez Engineering Inc. of Houston, Tex. The SPAS-II hardware is developed and manufactured by Messerschmitt-Bolkow-Blohm GmbH of Munich, Germany. Mounted on the SPAS-II are two sensor systems: an infrared spectrometer/radiometer built by Kayser-Threde of Germany housed in cryostat (cryogenically cooled instrument chamber) built by Linde of Germany and a multispectral Arizona Imager/Spectrograph (AIS) built by the University of Arizona at Tucson, Ariz.

## **Shuttle Pallet Satellite II (SPAS-II)**

The SPAS-II element incorporates a liquid helium cooled infrared sensor, the Arizona Imager/Spectrograph (AIS) multispectral sensor, two low light level television cameras and various support subsystems on a modular graphite-epoxy structure. SPAS-II will be deployed from the orbiter using the Remote Manipulator System (RMS) and will maneuver at ranges of up to 20 km from the orbiter to gather spectral and spatial data during several experiments.

## **Chemical Release Observation (CRO)**

The Chemical Release Observation (CRO) portion of the Infrared Background Signature Survey (IBSS) mission is an experiment designed to collect infrared, visible and ultraviolet time-resolved radiometric data associated with the release of liquid rocket propellants in near Earth



# IBSS SPACECRAFT

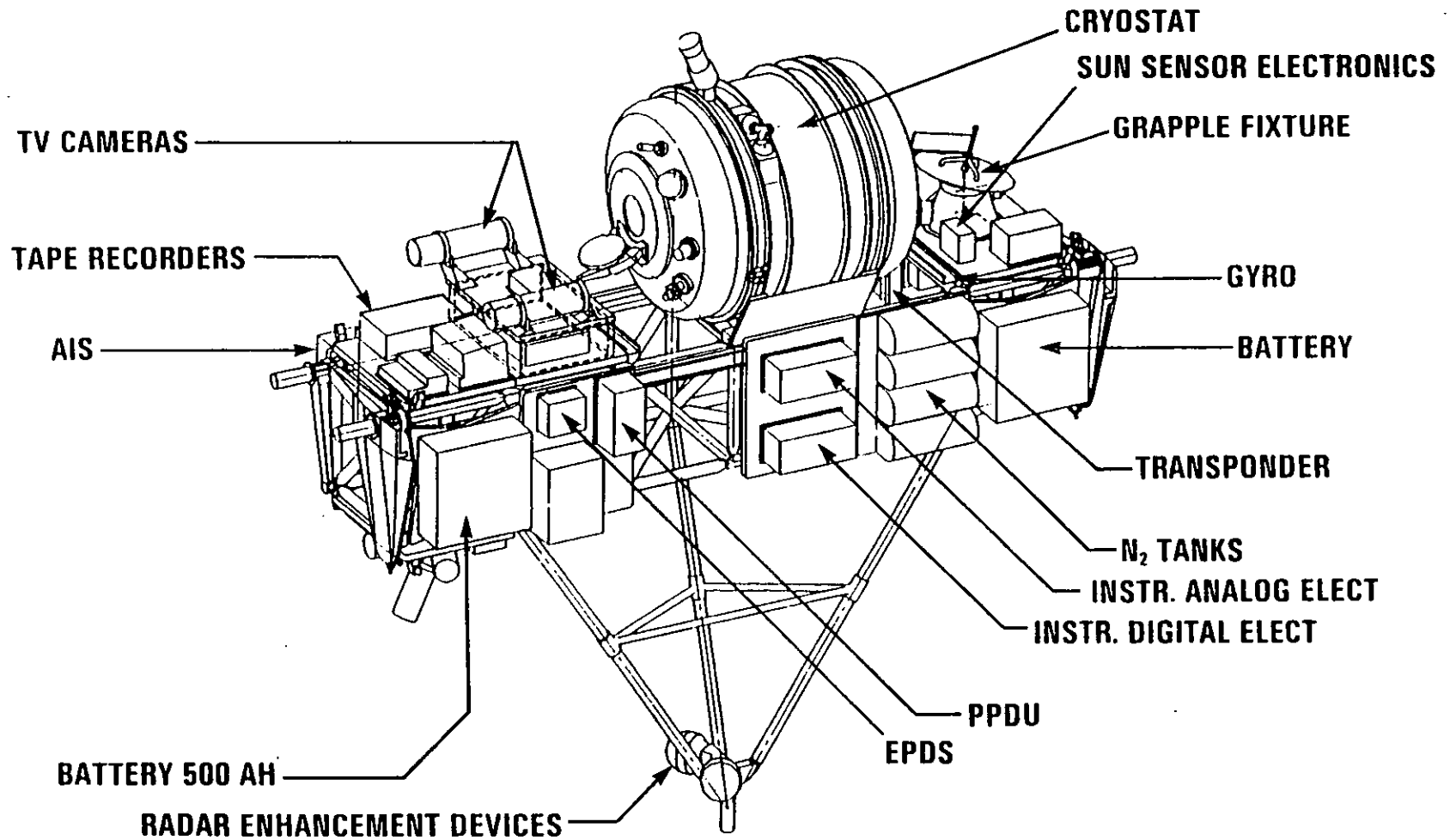

# CHEMICAL RELEASE OBSERVATION (CRO)

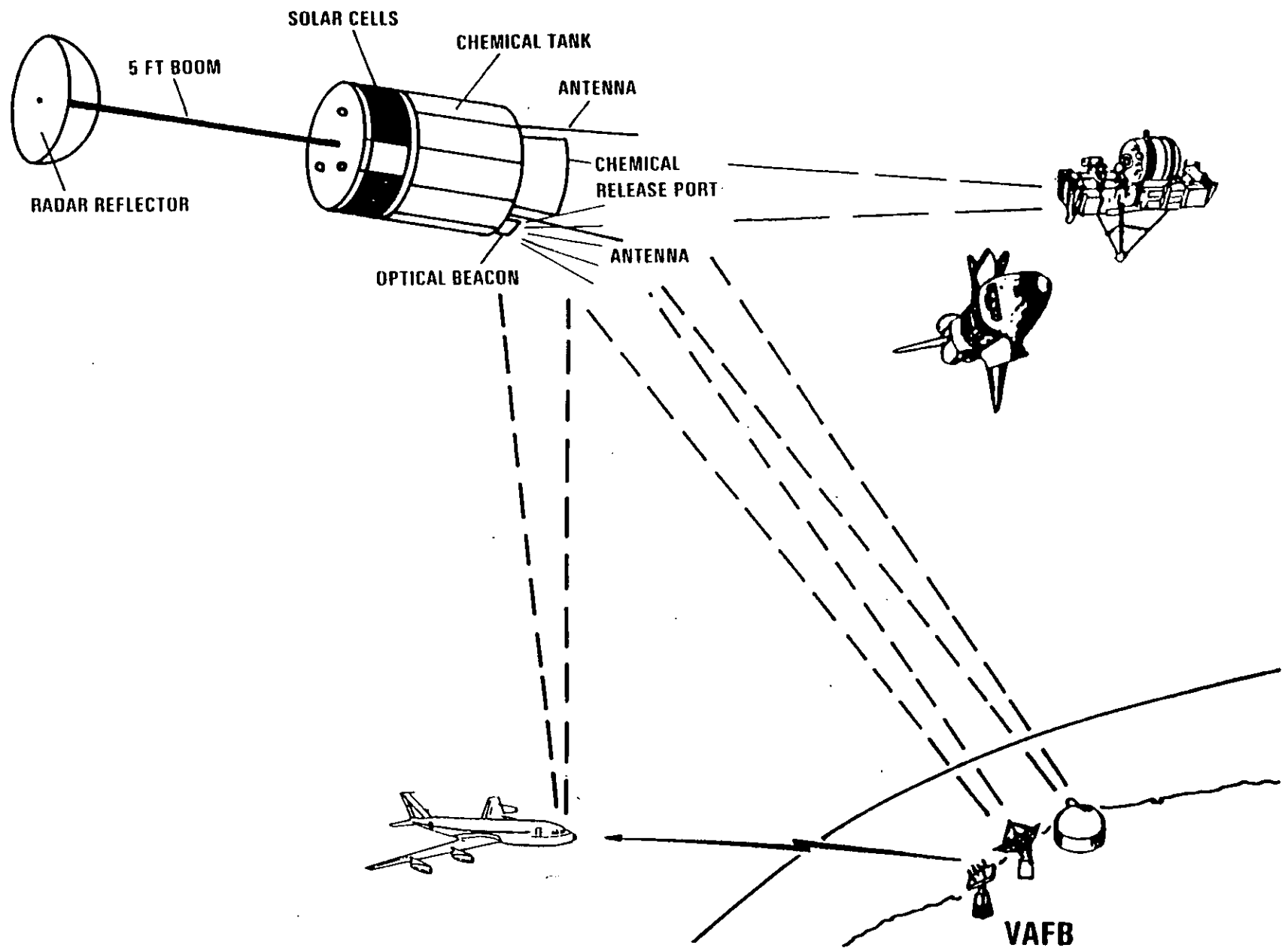

orbit. The experiment is composed of three separate subsatellites containing chemicals and their launchers.

Since the three chemical releases will produce short-lived clouds of vapor and frozen particles in orbit near the Shuttle, it is possible that a faint glow of visible light may occur due to the interaction of the vapor cloud with oxygen atoms in the upper atmosphere. It is not expected, however, that the vapor glow from any of the releases will be bright enough to be detected by the unaided eye on the ground. The chances of observers near Vandenberg seeing the first and only nighttime scheduled release experiment are very remote.

The cloud of frozen particles, however, can scatter sunlight producing visible light with much greater intensity. The sunlight scattered from the particle cloud will not be as intense as the daytime sky, however, so it is unlikely that either the second or third release can be viewed from the ground for the scheduled launch and mission time line. If the launch is delayed a couple of hours, however, the first scheduled release could occur under pre-dawn twilight conditions on the west coast. This situation would provide optimal viewing conditions as the release would occur in sunlight while a west coast observer would be in darkness. Under these conditions, the release would initially appear as a disk of white light approximately the size of the full moon (though somewhat dimmer). The cloud will continue to grow and gradually dim after the flow of liquid ends. The remnants of the bright cloud will only persist for a few minutes.

### CRO Management

The CRO element is managed by the Air Force Space Technology Center from their West Coast (Los Angeles) office. The CRO subsatellites and launcher mechanisms are designed and manufactured by Defense Systems Inc., of McLean, Va, while the launcher cylinders and support beams are provided by NASA/Goddard Space Flight Center at Greenbelt, Md. Subsatellite ground control and telemetry is provided by USAF 6595th Test & Evaluation Group and the Western Test Range at Vandenberg AFB, Calif., supported by Federal Electric Corp. Aircraft sensor platform operations for collecting CRO data in the VAFB area are provided by the HALO aircraft, operated by Phillips Laboratory's Weapons Directorate and 4950th Test Group at Kirtland AFB, N.M., supported by BDM Corp. of Albuquerque, N.M.

IBSS mission integration, launch site operations and payload flight operations are managed by the Space Systems Division, Air Force Systems Command, supported by The Aerospace Corporation and Rockwell International Space Division.

### **Critical Ionization Velocity (CIV)**

The Critical Ionization Velocity experiment will investigate the interaction of neutral gases with the ambient weakly-magnetized plasma.

The CIV element includes four compressed gas canisters (xenon, neon, carbon dioxide and nitrous oxide) which release plumes of the gas out of the orbiter bay upon crew command. The plumes are then observed by the SPAS-II sensors at different orientations to the orbiter's direction of travel and the local geomagnetic lines of force. The CIV hardware weighs about 500 lbs.

Kinetic energy of the gas will exceed its ionization potential due to its relative velocity with the ambient plasma. The resulting plasma instability is expected to enhance ionization. Charge exchange between the gases released and ambient ions (mainly oxygen) is expected to produce other ions.

Both mechanisms can lead to the release of radiation. Therefore, radiation in the infrared, visible and ultraviolet bands will be collected by the sensors from the deployed SPAS-II. The CIV experiment also has a data acquisition package, its radiometers will measure both visible and ultraviolet radiation from the payload bay. The CIV experiment, in the payload bay, has a Langmuir probe which will measure the ambient electron density and temperature.

Four different gases have been selected, and the release mechanism was designed such that the critical ionization velocity should be reached for three of the four gases when they are released in the RAM direction. Because the orientation and strength of the local magnetic field is expected to affect the intensity of the ionization phenomenon, the gas releases will be observed both when the local magnetic field is approximately parallel to RAM and when it is perpendicular to RAM. The effect of ambient electron density on the phenomenon will be observed by repeating the observations in both the daylight and darkness.

# CIV EXPERIMENT

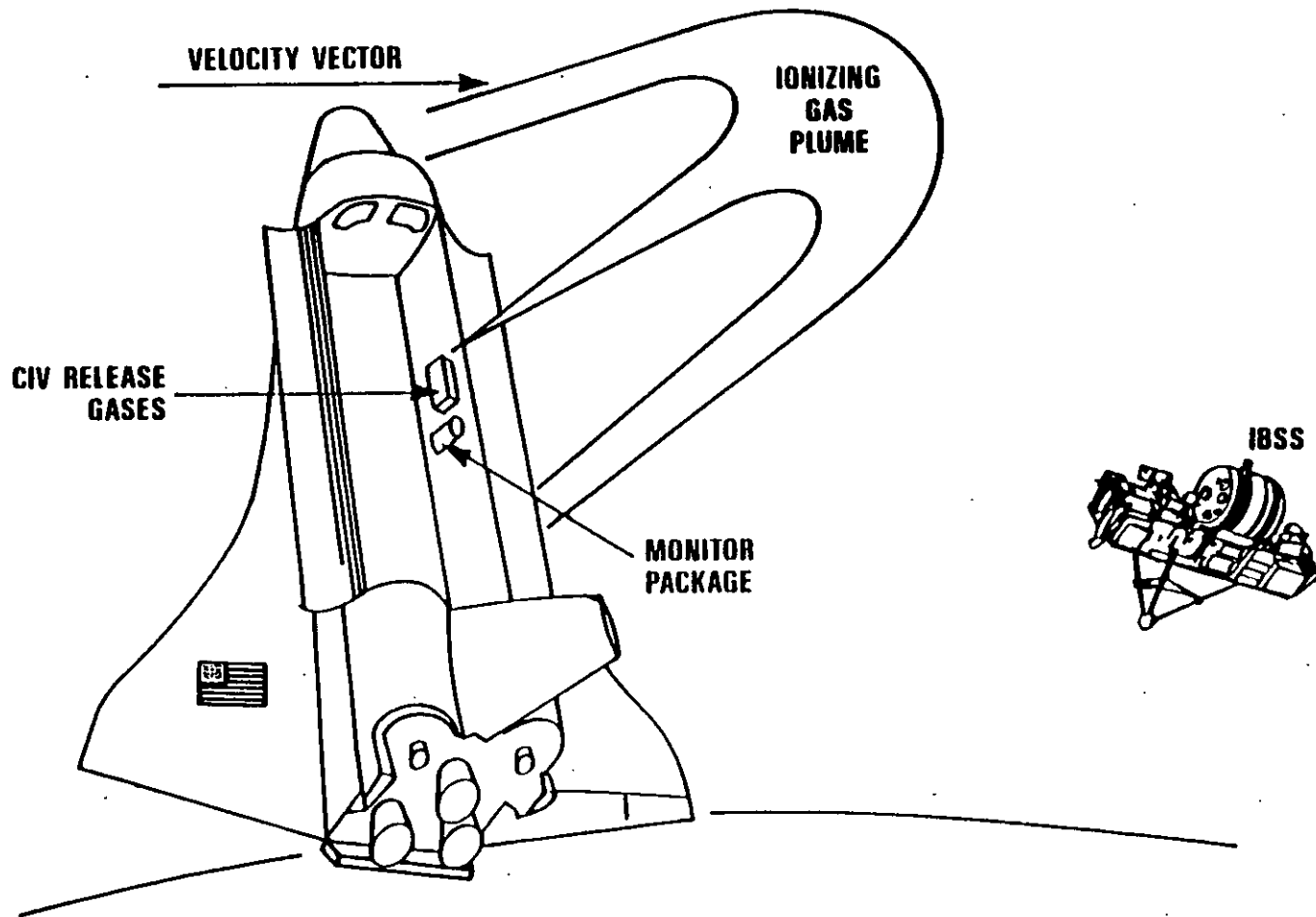

Four observations are planned with the SPAS-II deployed at a location near the Orbiter. Lighting and magnetic field orientation will be varied to produce four unique observations.

### CIV Management

The CIV element is managed by Geophysics Laboratory/Space Physics Division at Hanscom AFB, Mass. Supporting contractors include:

Physical Sciences Inc., Andover, Mass.	Gas Release System & System Integration
Northeastern University, Boston, Mass.	Payload Support System Manufacturer
Wentworth Inst. of Tech, Boston, Mass.	General Mechanical Mfg.
John Hopkins University, Baltimore, Md.	Pressure Gauge Subsystems
Research Science Inc., Washington, D.C.	Radiometer Subsystem
University of Iowa, Iowa City, Iowa	Langmuir Probe

### IBSS Objectives

The Infrared Background Signature Survey is a Strategic Defense Initiative Organization sponsored program for the purpose of obtaining scientific data for use in the development of ballistic missile defense sensor systems. The IBSS mission will involve the collection of infrared, ultraviolet and visible measurements of natural and induced geophysical phenomena.

Using the SPAS-II sensors at various ranges from the orbiter, spectral, spatial and temporal radiometric observations will be made of the exhaust plumes when the orbiter's orbital maneuvering systems (OMS) fires and creates replications of ICBM booster and midcourse engine firings. Interaction of the outer plume regions with the atmosphere will be characterized, as well as the region near the exit nozzle. The single engine OMS firings for these observations represent the first time such firings have been attempted in space by the orbiter.

The Chemical Release Observations (CRO) will be carried out by deploying each of the three CRO subsatellites from the cargo bay at about 3.5 feet per second, allowing them to separate until the subsatellite trails the SPAS-II by 50 to 200 km in orbit. Release will be timed such that, at that range, the CRO subsatellite will pass over Vandenberg AFB (VAFB) in Southern California. A signal from VAFB will cause the subsatellite to send telemetry measurements of its health and status. Then another signal (moments later on the same pass or on the next pass) will cause the subsatellite to expel a stream of chemical which will quickly vaporize into a cloud, while being observed from SPAS-II sensors, ground sensors at VAFB and airborne sensors on the ARGUS aircraft, simultaneously. Spectral information will permit characterization of the chemical interactions with the atmosphere and solar energy, as well as determine the aerosol distribution of the chemicals with respect to particle size and expansion rate. The chemicals released are 15 pounds of nitrogen tetroxide, 52 pounds of unsymmetrical dimethyl hydrazine and 60 pounds of monomethyl hydrazine, released in that order. These observations will assist the SDIO in characterizing the signature from liquid fuel clouds escaping from damaged ICBM boosters.

The subsatellites will be tracked and commanded by personnel from the USAF 659th Test and Evaluation Group, supported by Federal Electric Corporation, using assets of the Western Test Range at VAFB. Aircraft sensor platform operations for collecting CRO data in the VAFB area are provided by the Strategic Defense Initiative Organization's High Altitude Observatory (HALO) aircraft operated by Aeromet Inc., Tulsa, Okla., with instrument support by Automated Sciences Group, Inc., Huntsville, Ala. for the U.S. Army Strategic Defense Command.

The CIV experiment is intended to provide on-orbit spectral data to examine a theory which holds that many gases (including rocket combustion products) can be ionized if they are passed through a magnetized plasma and their kinetic energy is caused to exceed their ionization potential. Ions so created would then flow along the local magnetic lines of force and generate emissions which can be detected by space-borne sensors, thereby permitting tracking of the vehicle releasing the gases. In the CIV experiment, gases under pressure will be ejected at different angles to the orbiter velocity (such that collisions with the thin orbital atmosphere will enhance ionization) and to the local magnetic field lines. The SPAS-II will be "parked" about 2 km away, taking spectral data on the gas plumes, and other instruments in the CIV package (radiometers and a Langmuir probe) will take data as well. The gases used will be xenon (low ionization potential - should definitely ionize), neon

(very high potential - should not ionize), carbon dioxide and nitric oxide (typical exhaust products form hypergolic fueled rockets).

SPAS-II also will be used to take spatial and spectral measurements of the Earth's atmosphere as viewed at the horizon (called the "Earth's limb" at various altitudes above the surface. Such data is necessary to establish the background against which an approaching ICBM would be viewed by a sensor system as the ICBM came over the horizon. For the same reason, measurements will be taken of the Earth's surface under many conditions of light and darkness, hard earth and water, clouds and cloudlessness. Yet another geophysical type of data which will be measured for the same reasons will be auroral emissions (Northern and Southern Lights) as available.

Finally, to characterize the effects of contaminating materials coming from a sensor platform itself, the environment around the orbiter will be measured by the SPAS-II "parked" nearby. These measurements will be taken with the orbiter in a "quiet" state, as well as during fuel cell purges, water dumps, thruster firings and other contaminating events. Measurements also will be taken of the "orbiter glow" phenomenon. This phenomenon occurs where the rarified atmosphere strikes orbiter surfaces, especially the tail, causing visible and infrared radiance. Theories on the mechanism, including reactions with atomic oxygen, chemiluminescence and gas phase collisions, will be investigated and hopefully better understood. This phenomenon also may occur on orbiting SDI sensor platforms or target ICBM vehicles.

### **IBSS Plume Observations**

The objective of the plume experiment is to gather data on the optical signature of rocket plumes. The experiment should permit the characterization of the plumes through spectral, spatial and temporal radiometric measurements in the infrared, ultraviolet and visible bands.

Observations will be made of the plumes generated by the orbiter engine firings. The outer regions of the plumes will be examined to determine the interaction with the atmosphere. Observations also will be made to measure the radiative properties near the exit nozzle.

### **Earth Background Experiments**

The Earth Background experiments will use the IBSS Infrared Sensor and the AIS sensors to characterize the Earth background from the Earth's



limb to the hard earth and in areas around the solar specular point. Measurements will consist of Earth's limb and Earth scan observations with SPAS deployed, auroral observations with SPAS on the RMS, and AIS Earth's limb observations from in the bay.

The Earth's limb observations will include day, night and terminator views. The Earth scan observations are directed at the Earth rather than the limb. These include observations of spatial clutter in CO2 bands, observations of areas around the solar specular point, the terminator and limb to Earth scans.

### **Orbiter Environment Experiment**

The Orbiter Environment Experiment is an experiment to be performed by the IBSS payload. The orbiter environment observation will use the IBSS infrared sensor and the AIS sensors to characterize the contaminant environment in and around the orbiter payload bay. Observations will be in the infrared, visible, and ultraviolet regions of the spectrum. Observations also will be made of the orbiter glow phenomenon.

During orbital operations, water dumps are made and thrusters are fired. Gases are released when materials are exposed to the vacuum environment of space. This experiment will observe these and other contaminants in the payload bay.

A diffuse near-field glow phenomenon has been observed above spacecraft surfaces subjected to the impact of atmospheric species as the spacecraft travels through the low-Earth orbital atmosphere. It is thought that this phenomenon results from some type of interaction between the ambient atmosphere and the spacecraft surface. Sufficient data does not exist to fully understand the process. A number of mechanisms have been proposed which could give rise to the glow. These include: (1) gas phase collisions, (2) surface-aided chemiluminescence reactions with adsorbates on orbiter surfaces, and (3) surface reactions with the atomic oxygen environment leading to material loss or compositional changes.

The spectrum of the glow is relatively diffuse and based primarily in the red-infrared region. The glow intensity is dependent upon the surface orientation to the velocity vector. The glow intensity seems to vary as a function of the atomic oxygen density. The glow intensity seems to vary depending upon the type of material.

## **IBSS Participants**

### Program Management

Strategic Defense Initiative Organization.  
Washington, D.C.

### Integration of Payload and Operations with Shuttle

HQ Space Systems Division  
Los Angeles Air Force Base, Calif.

The Aerospace Corporation  
Los Angeles, Calif.

Federal Electric Corporation  
Vandenberg Air Force Base, Calif.

Rockwell International  
Downey, Calif.

6595th TEG/DTR and Western Test Range  
Vandenberg Air Force Base, Calif.

### Develop Payload

Strategic Defense Initiative Organization  
Washington, D.C.

Messerschmidt-Bolkow-Blohm  
Germany

Defense Systems, Inc.  
McLean, Va.

Physical Sciences, Inc.  
Andover, Mass.

Orbital Systems, Ltd.  
Lanham, Md.

SKW Corporation  
Arlington, Va.

Nichol Research Corp.  
McLean, Va.

Geophysics Directorate of Phillips Laboratory  
Hanscom Air Force Base, Mass.

Phillips Laboratory's West Coast Office  
Los Angeles Air Force Base, Calif.

University of Arizona  
Tucson, Ariz.

### Training

Hernandez Engineering Corp.  
Houston, Texas

## **STS-39 SPAS/IBSS RENDEZVOUS & TRACKING OPERATIONS**

Rendezvous and tracking maneuvers in support of IBSS operations during STS-39 present many significant challenges to Space Shuttle mission operations. More than 60 orbiter maneuvers are planned to support the various phases of SPAS/IBSS rendezvous, including IBSS calibrations, deployment, separation, far-field observations, near-field observations, CRO subsatellite deployments and observations, and SPAS retrieval and berthing.

### **Separation to Far-field**

Following the deployment of the SPAS/IBSS imaging platform, the crew will perform an acceleration, or posigrade burn, firing Discovery's reaction control system (RCS) thrusters to raise Discovery's orbit about 1 statute mile above the SPAS. The effect of this maneuver will drift Discovery to a point about 6 1/2 statute miles behind the SPAS, the required distance for far-field observations. Arriving at that point one orbit after the separation burn, the crew will fire the RCS to brake Discovery and place it again in the same orbit with the SPAS. Deployment and separation are scheduled to occur while both crew shifts are awake.

## Far-field Operations

Following a crew shift handover at the far-field position, the Red Team will maneuver Discovery to point its nose north, with the payload bay pointed in the direction of orbital travel -- toward SPAS, 6 1/2 miles ahead.

## OMS Plume Observation

From this position, the crew will remotely command the SPAS/IBSS to point its imaging systems at Discovery for the first plume observation. Once the experiments are properly trained on Discovery, one orbital maneuvering system (OMS) engine will be fired for 20 seconds. The result of the burn will be to propel Discovery north, off of its previous orbital groundtrack, without changing the spacecraft's altitude. A burn with this lateral effect is known as "out-of-plane." Immediately following the burn, the crew will perform a "fast-flip" yaw maneuver, using RCS jets to turn Discovery's nose around 180 degrees to the south. A single-engine OMS braking burn then will be performed to stop Discovery's travel at a point less than a mile north of its previous groundtrack. Using RCS jets, the crew will return Discovery to its starting position, on its original groundtrack behind the SPAS. As Discovery drifts back to the starting point, a "fast-flip" reversal will turn the spacecraft's nose back to the north. Throughout this sequence, the crew will point the SPAS/IBSS by remote control to observe each burn.

Far-field observations will continue following the Blue Team's sleep shift. Due to the complexities involved, all OMS burns will be conducted only when both crew shifts are awake and able to participate.

Discovery will remain at the far-field position during the Blue Team's sleep, and the Red Team will continue SPAS/IBSS operations, conducting Earth's limb observations by remote control.

Following the Blue Team's sleep shift, while both teams are awake, the same sequence of maneuvers will be repeated twice in support of two additional plume observations.

## PRCS Plume Observation

The final IBSS objective at the far-field position will be an observation of Discovery's primary RCS jets firing. In the same attitude used for OMS plume observations, the crew again will align SPAS/IBSS to

train it's optics on the vehicle and then ignite one of the primary thrusters for 25 seconds.

#### Far-field CRO Release

After the far-field plume observations have been completed and while the Red Team sleeps, the Blue Team will eject the first CRO canister from the payload bay at a rate of 3.5 feet per second (fps) to an altitude just above that of Discovery and SPAS.

Just after it is ejected from the payload bay, antennae on the canister will deploy, providing a remote command link to investigators at Vandenberg Air Force Base (VAFB). The canister will drift during several orbits to the desired distance for IBSS imaging, where VAFB investigators will remotely command the canister to release its gaseous contents. CRO gas releases and observations will begin after near-field operations have been completed.

#### Transition to Near-field

To reach the near-field observations position, the crew will perform a slowing, or retrograde, RCS burn to slightly lower Discovery's orbit. The effect of the burn, over the next orbit, will move Discovery to within 1.5 statute miles behind the SPAS. As Discovery approaches that point, another RCS burn will brake the orbiter, placing it directly behind SPAS on the same orbital path, less than 1.5 miles behind.

#### Near-field Operations: OMS Plume Observations

At the near-field position with both crew teams awake, Discovery again will be maneuvered to the "nose-north" start attitude which was used for far-field observations. The same out-of-plane OMS burn sequence will be repeated twice for near-field plume observations. The crew will continue to point the SPAS/IBSS imaging systems by remote control to set up and record each observation.

#### Near-field Operations: CIV Observations

Before leaving the near-field position, the crew will train SPAS/IBSS imaging systems on Discovery's payload bay to observe and document a sequence of gas releases from CIV canisters mounted in the bay.

## CRO Observations

Following completion of near-field operations while the Blue Team sleeps, the Red Team will conduct a series of maneuvers to set up IBSS imaging and tracking of the CRO gas-release canisters ejected from Discovery's payload bay.

A combination burn, both posigrade and out-of-plane, will be made to further separate Discovery from the SPAS and avoid obscuring its view of the already deployed canister. The posigrade component of the RCS burn will provide for a slow separation from the SPAS, over 7.5 hours and five orbits, to a distance of 9 miles behind SPAS for the start of retrieval operations. The lateral component will move Discovery off of the direct track between SPAS and the CRO canister so it will not block the line of sight of the SPAS imaging experiments.

During this five-orbit separation phase, the crew will remotely command the SPAS/IBSS to track and observe the first CRO canister as VAFB ground controllers remotely command the gas release.

Following completion of the first CRO observation, the crew will perform an RCS burn to move Discovery back into alignment with the flight path of the SPAS, but continuing to separate. The crew will then eject a second canister and command the SPAS/IBSS to track and observe another ground-commanded gas release.

## SPAS/IBSS Retrieval

After separating to more than 9 statute miles and with both crew shifts awake again, a retrograde burn will slightly lower Discovery's orbit to overtake the SPAS/IBSS. Several course adjustment burns may be conducted as Discovery nears its target, in order to arrive directly in front of the SPAS on the same flight path. The crew then will manually maneuver Discovery to within range of the remote manipulator system for capture.

# **STP-1**

## **Overview**

The STP-1 payload is sponsored by the USAF Space Systems Division. It is a complex secondary payload with experiments that are monitored and controlled by the Hitchhiker avionics. The Hitchhiker equipment for the payload consists of the support structure, the avionics and the experiment containers. This equipment is managed by NASA's Goddard Space Flight Center (GSFC). GSFC also provides a carrier, power and communications to the various experiments aboard. The experiments are contained in Get Away Special (GAS) canisters which are already certified for space. GSFC also completes the integration and testing for the experiments.

STP-1 is composed of five separate experiments: the Ultraviolet Limb Imaging (UVLIM) experiment, the Advanced Liquid Feed Experiment (ALFE), the Spacecraft Kinetic Infrared Test (SKIRT), the Data System Experiment (DSE) and the Ascent Particle Monitor (APM).

STP-1 is considered a secondary payload which means it may not interfere with the two primary payloads. Only a short portion of dedicated time is allocated to the payload, and at other times the experiments are conducted on a non-interference basis.

After the Shuttle is in orbit and the payload bay doors are open, the crew will power on the payload. The payload then will be commanded from the ground by a control center located at GSFC. The control center will be operated 24 hours a day to coincide with the 24-hour operations of the Shuttle crew. The control centers for the two primary payloads are located at NASA's Johnson Space Center. There will be constant coordination between the control centers during the flight to execute the mission and to replan should the need arise.

## **Hitchhiker Project**

The Hitchhiker Project, operated by Goddard Space Flight Center (GSFC) in Greenbelt, Md., provides for accommodation of small payloads in the Shuttle payload bay. The Hitchhiker payload for STS-39 is called Space Test Payload-1 (STP-1) and consists of a Hitchhiker cross-bay carrier with five experiments. The carrier hardware includes the cross-bay structure, carrier avionics unit, mounting plates, canisters and a motorized canister door. STP-1 is sponsored by the U.S. Air Force Space Systems Division.

# STP-1 CONFIGURATION

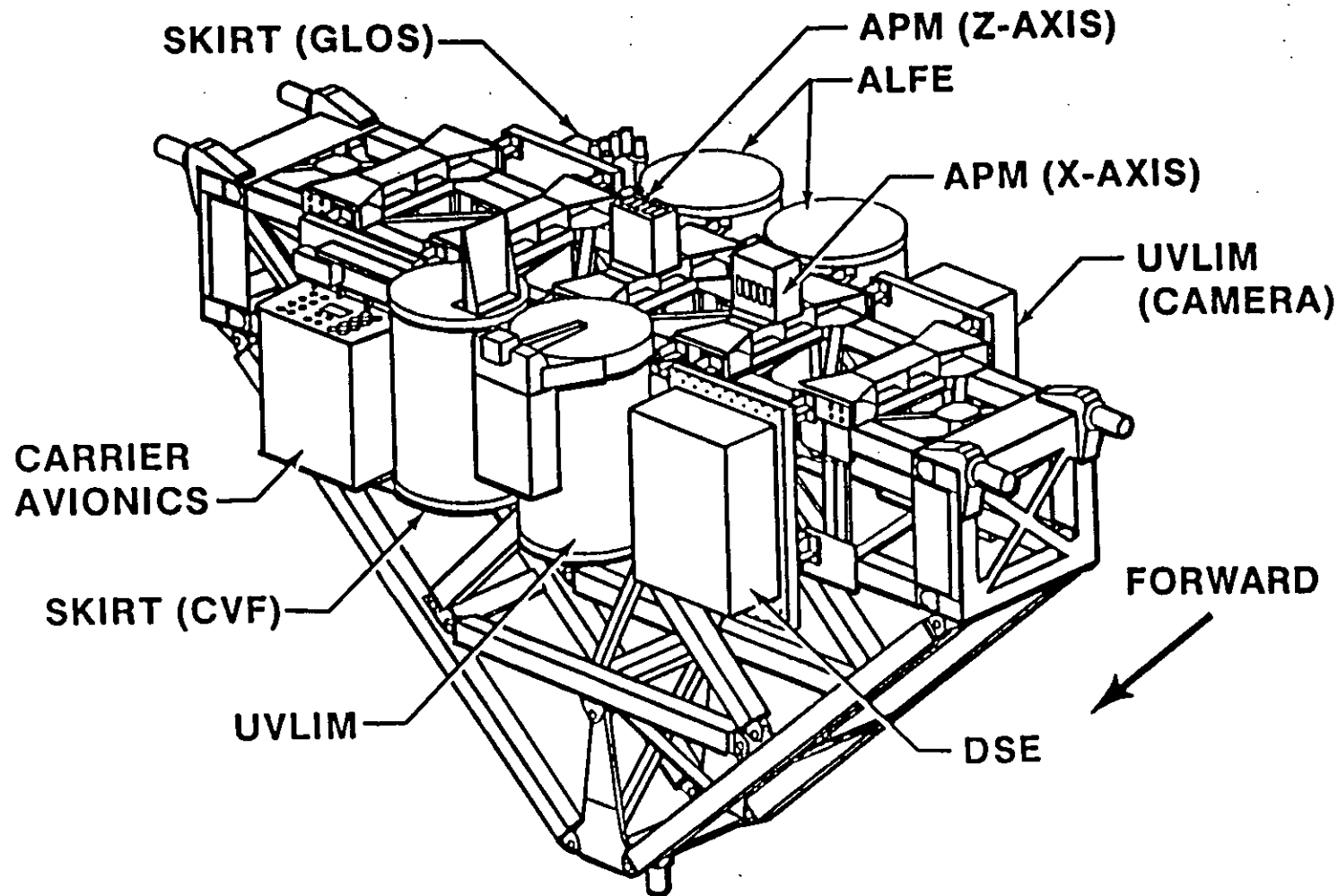



Hitchhiker was designed and built at Goddard and will be operated from a control center at GSFC during the mission. The five experiments on STP-1 are:

The Hitchhiker Project is operated by GSFC for the NASA Office of Space Flight. Payloads are provided thermally controlled mounting surfaces or sealed pressurizable canisters, orbiter power, command and data interfaces.

The last Hitchhiker mission was in 1986, and the next after STS-39 will be in August 1992, followed by another in October of that year.

GSFC Project Manager and Deputy Project Manager are Theodore Goldsmith and Steven Dunker. Chuck Chidekel, also of Goddard, is Integration Manager. The USAF STP-1 Program Manager is Capt. Hau Tran, and NASA Headquarters Program Manager is Edward James.

### **Ultraviolet Limb Imaging (UVLIM) Experiment**

The objective of the Ultraviolet Limb Imaging experiment, sponsored by the Naval Research Laboratory in Washington D .C., is to measure the vertical and geographic distribution of the ultraviolet airglow in the wavelength region from 575 angstroms to 1900 angstroms.

These measurements will be used to determine the daily and seasonal variation of the composition of the ionosphere and neutral atmosphere between the altitudes of 100 and 500 kilometers. The UVLIM experiment requires a 5 cubic foot canister with a motorized door and a mounting plate to house a 35mm aspect camera. The camera will be aligned with the experiment aperture plate to provide simultaneous data which will be correlated with post flight data in determining point location.

The experiment uses an extreme ultraviolet imaging spectrometer with a two dimensional detector to make images of the horizon from the airglow emissions which characterize the composition of the ionosphere. The far ultraviolet spectrometer measures emissions indicative of the temperature and composition of the neutral atmosphere.

### **Advanced Liquid Feed Experiment (ALFE)**

The next generation of spacecraft and space tugs may be one step closer to autonomous operation and longer life due to the technology to be

demonstrated in space by the Advanced Liquid Feed Experiment (ALFE). The space flight experiment is designed to evaluate the performance of key components of an advanced spacecraft propulsion system designed and built by the McDonnell Douglas Astronautics Company (MDAC) under contract to the Phillips Laboratory's Astronautics Directorate.

ALFE will provide the first space flight demonstration of an electronic pressure regulator and a series of ultrasonic propellant level and flow sensing systems. These components will provide the capability to remotely and electronically control the pressurization schedule of spacecraft propellant tanks to accurately gauge the available on-board propellants and to reliably track the propellant usage throughout the mission. The experiment also will demonstrate the capability to integrate all storable propellant on-board the spacecraft by transferring attitude control system propellants into the main engine tanks and vice versa.

The experiment is designed to use commercially available components to build two hardware modules weighing approximately 250 pounds each. The first module is an electronic package which will function as the remote test conductor aboard the Shuttle. It contains an on-board computer and associated electronics necessary for performing the experiment and recording the data. The module will provide the command and control for the experiment. It also will provide the communication link to transfer experiment telemetry and video signals to the ground based operator located at NASA's Goddard Space Flight Center (GSFC).

The second module is the fluid system module. It contains two test tanks, an electronic pressure regulator, an ultrasonic liquid gauging system and the associated instrumentation, pumps and valves. The items of interest are the test tanks, the electronic pressure regulator and the ultrasonic liquid gauging system.

The test tanks are made of Plexiglas and are scaled to represent a 1/4 scale of the actual system. Internally, each of these tanks is fitted with a liquid acquisition device for liquid positioning in the low gravity environment of space, and a screen device to preclude the ingestion of gas bubble into the lines. During the experiment, various quantities of fluid will be transferred between two tanks to simulate a hypothetical resupply scenario in space.

The electronic pressure regulator, built by Parker Hannifin of Irvine, Calif., will control the pressure of the test tank during flight. It has a unique capability to provide a smooth ramp-up of tank pressure when

commanded in contrast with the typical burst disk system. The regulator also has the capability to control the downstream pressure to different pressure settings. This will enable better management of the limited quantity of the precious pressurized gas carried by the spacecraft.

The ultrasonic liquid gauging system, supplied by Panametrics in Waltham, Mass., will provide an advanced approach to measure and track the liquid propellant usage. The system consists of a group of six ultrasonic point sensors and an ultrasonic flow cell. The point sensors, using the pulse-echo effect, measure the time delays for the ultrasonic pulses and their echoes to transit through the fluid to the gas-liquid interface. From these time measurements, the amount of the liquid contained within the tank can be calculated. Using a similar approach, the ultrasonic flow cell measures the time delay between two simultaneous ultrasonic pulses along a fluid line to calculate the propellant flow.

When flown, the ALFE on-board computer will accept commands from the ground based operator located at NASA's GSFC and will configure the payload for the desired test sequence. An internal wide angle television camera will record the fluid settling characteristics under various acceleration loads. Experiment data will be both stored on-board in the electronic module and transmitted to the ground based operator. The results will be used in further updating the design of the advanced spacecraft feed system.

### **Spacecraft Kinetic Infrared Test (SKIRT)**

The Spacecraft Kinetic Infrared Test (SKIRT), sponsored by Phillips Laboratory's Geophysics Directorate, consists of two separate and independent components.

The Gaseous Luminosity of Optical Surface (GLOS) consists of infrared, visible and ultraviolet radiometers combined into one package weighing 50 pounds. The Circular Variable Filter (CVF) is a solid nitrogen cooled infrared spectrometer/radiometer mounted in a sealed canister with an aperture in the top plate. A motor driven cover is commanded open and closed on-orbit to cover the aperture as needed. A "glow plate" attached to the top plate provides a surface for impingement of the residual atmosphere to produce the glow which is then observed by the spectrometer. CVF weighs approximately 150 pounds with cryogen.

The experiment objective is to obtain infrared spectral measurements of the Shuttle glow at resolutions and sensitivity that will allow

identification of the chemical species associated with this phenomenon. Since the Shuttle glow effect is thought to be caused by the impact of atomic oxygen on the orbiter surfaces, it is only necessary that surfaces near the SKIRT field-of-view be exposed to ram (direction) at various times during the mission.

### **Ascent Particle Monitor (APM)**

The Ascent Particle Monitor (APM), sponsored by USAF Space Systems Division's Operating Location detachment in Houston Texas, consists of a small box with a fixed door and a movable door mounted in a clamshell arrangement atop an aluminum housing. Each door contains six coupon holders into which selected passive witness samples are installed. The door is closed preflight to protect the coupons from the environment. It is opened after ground operations are completed and the payload bay doors are about to be closed in preparation for launch. A motor/gearbox assembly, two battery packs, launch detection circuitry and door opening circuitry are contained within the aluminum housing of the unit. The electric motor is used to open and close the door so that particles can be collected at specific times during Shuttle ascent. An internal timing circuit set prior to installation of the APM into the orbiter payload bay to control the door movement. The timer circuit is acoustically actuated by orbiter main engine start.

The concept of the APM experiment evolved as a direct response to concerns by the spacecraft community about the fallout of particles in the Shuttle orbiter payload bay during the ascent portion of the missions. Particulate contaminants on Shuttle bay surfaces and on surfaces of payloads in the cargo bay may be released during launch and ascent by vibroacoustic, gravitational and aerodynamic forces. These particles can be deposited on surfaces from which they were released or on other surfaces depending on location acceleration and velocity vectors with respect to such surfaces.

Many analytical models of particle redistribution have been made using assumed ascent forces during launch, but most models are based on uniform redistribution of particles. Insufficient experiment data exist on particle fallout and deposition during Shuttle ascent to verify current models. The understanding of particle redistribution on surfaces and releases of particles into the field of view of instruments incorporating critical sensors is important in view of the influence the particles may have on the properties of the surfaces on which they are deposited and on

the optical degradation of the environment into which they may escape. Some of the effects of particles on surfaces and in the environment are physical obscuration of the surface, scattering of radiation which changes the transmitting or reflecting properties, increased diffuse reflection of the surface, and emission of radiation by the particles which may be detrimental to certain sensors.

The first APM flew on the STS-28 mission and the flight coupons were analyzed in the Materials Science Laboratory of the Aerospace Corporation in Los Angeles, Calif. Various analytical techniques were used to evaluate the contaminants, including optical and scanning electron microscopy, infrared spectroscopy and energy dispersive X-ray spectroscopy. The coupons also were examined at NASA's Goddard Space Flight Center at Greenbelt, Md., using bidirectional reflectance distribution function scatter measurements. The APM also flew on STS-31 (Hubble Space Telescope), and is manifested on STS-37 (Gamma Ray Observatory payload).

#### **Data System Experiment (DSE)**

The Data System Experiment (DSE), sponsored by NASA's Goddard Space Flight Center in Greenbelt, Md., consists of a MILVAX computer, Erasable Optical Disk, and associated simulators and interfaces. The simulators would generate data to be used to exercise the computer and the optical disk.

The objective of the DSE is to evaluate the performance of the computer and disk in a micro gravity environment. The optical disk system stem consists of an erasable optical disk drive unit and a removable cartridge media. Both are designed for reliable use under a variety of environmental conditions.

## **STP-1 PARTICIPANTS**

### **Overall Project Management**

Space Systems Division, Los Angeles AFB, Calif.

Responsible for integration of flight hardware, production of flight and ground safety packages, and performance of all integrated systems testing:

NASA's Goddard Space Flight Center, Greenbelt, Md.

### **Organizations Responsible for the Experiments**

Naval Research Laboratory

Washington, D.C.

Ultraviolet Limb Imaging Experiment (UVLIM)

Phillips Laboratory's Astronautics Directorate

Edwards Air Force Base, Calif.

Advanced Liquid Feed Experiment (ALFE)

Hanscom Air Force Base, Mass.

Spacecraft Kinetic Infrared Test (SKIRT)

USAF Space Systems Division

Detachment OL-AW, Houston, Tex.

Ascent Particle Monitor (APM)

NASA's Goddard Space Flight Center

Greenbelt, Md.

Data System Experiment (DSE)

## **MULTI-PURPOSE EXPERIMENT CANISTER (MPEC)**

The Multi-Purpose Experiment Canister (MPEC) carries a classified experiment sponsored by the USAF Space Systems Division (SSD). The canister, a modified Get Away Special (GAS) container, is mounted on a beam attached to the starboard sidewall of orbiter cargo bay 6. The modified canister includes a 9-inch extension containing an ejection kit, electronics and a full diameter motorized door assembly.

The experiment is scheduled to be deployed from the cargo bay on the last day of the mission. However, deployment can occur earlier on a contingency basis. The crew provides power to the MPEC via the standard switch panel located in the crew compartment. The crew will send a command to open the canister door and, after verifying that the door is open, will arm the ejection mechanism and send the deployment command. The experiment is ejected with a relative velocity of about 2.7 ft/sec by a spring mechanism. After ejection, the canister door will be closed and power removed from the canister.

## **CLOUDS 1A**

The overall objective of the CLOUDS-1A program is to quantify the variation in apparent cloud cover as a function of the angle at which clouds of various types are viewed.

The CLOUDS-1A experiment is stowed in a middeck locker and consists of a Nikon F3/T camera assembly and film. On-orbit, a crew member will take a series of high resolution photographs of individual cloud scenes, preferably high "wispy" cirrus clouds, over a wide range of viewing angles.

## **RADIATION MONITORING EQUIPMENT-III**

Radiation Monitoring Equipment-III (RME-III) measures the rate and dosage of ionizing radiation to the crew at different locations throughout the orbiter cabin. The hand-held instrument measures gamma ray, electron, neutron and proton radiation and calculates the amount of exposure. The information is stored in memory modules for post-flight analysis.

RME-III will be stored in a middeck locker during flight except for when it is turned on and when memory modules are replaced every 2 days. It will be activated as soon as possible after achieving orbit and will operate throughout the flight. To activate the instrument, a crew member will enter the correct mission elapsed time.

The instrument contains a liquid crystal display for real-time data readings and a keyboard for function control. It has four zinc-air batteries and five AA batteries in each replaceable memory module and two zinc-air batteries in the main module.

RME-III, which has flown on STS-31 and STS-41, is the current configuration, replacing the earlier RME-I and RME-II units.

The Department of Defense, in cooperation with NASA, sponsors the data gathering instrument.



## **STS-39 CREW BIOGRAPHIES**

**Michael L. Coats**, 45, Capt., USN, will serve as commander. Selected as an astronaut in 1978, he considers Riverside, Calif., his hometown. STS-39 will be Coats' third space flight.

Coats was pilot on STS-41D, launched Aug. 30, 1984, the maiden flight of Discovery. Coats next commanded mission STS-29 aboard Discovery, launched March 13, 1989, to deploy a Tracking and Data Relay Satellite.

Coats graduated from Ramona High School, Riverside, in 1964, received a bachelor of science from the U.S. Naval Academy in 1968; a master of science in the administration of science and technology from George Washington University in 1977; and a master of science in aeronautical engineering from the U.S. Naval Postgraduate School in 1979.

He was designated a naval aviator upon graduation from Annapolis in 1969 and was assigned to Attack Squadron 192 aboard the USS Kitty Hawk for 2 years, flying 315 combat missions in Southeast Asia. He then served as a flight instructor with the A-7E Readiness Training Squadron at the Naval Air Station in Lenmoore, Calif., for a year before attending the Naval Test Pilot School. Afterward, he was project officer and test pilot for the A-7 and A-4 aircraft for 2 years before becoming a flight instructor at the Test Pilot School in 1976.

Coats has logged more than 5,000 hours of flying time in more than 28 different aircraft and 264 hours in space.

**L. Blaine Hammond, Jr.**, 38, Major, USAF, will serve as Pilot. Selected as an astronaut in 1984, Hammond was born in Savannah, Ga., and will make his first space flight.

Hammond graduated from Kirkwood High School, Kirkwood, Mo., in 1969; received a bachelor of science in engineering science and mechanics from the U.S. Air Force Academy in 1973; and received a master of science in engineering science and mechanics from the Georgia Institute of Technology in 1974.

Hammond earned his wings at Reese Air Force Base, Texas, in 1975 and was assigned to the 496th Tactical Fighter Squadron, Hahn Air Base, Germany, flying the F-4E. In 1979, he spent a year at Williams Air Force Base, Ariz., flying the F-5B/E/F and training foreign students. Hammond then attended the Empire Test Pilot School at A&AEE Boscombe Down,

England. He returned to Edwards Air Force Base in 1982 and was assigned as an instructor at the Air Force Test Pilot School, a position he held at the time of his selection by NASA.

Hammond has logged more than 3,100 hours flying 15 different American and 10 different English aircraft.

**Gregory J. Harbaugh, 34,** will serve as Mission Specialist 1 (MS1). Harbaugh, selected as an astronaut in 1987, considers Willoughby, Ohio, to be his hometown and will make his first space flight.

Harbaugh graduated from Willoughby South High School in 1974; received a bachelor of science in aeronautical engineering from Purdue University in 1978; and received a master of science in physical sciences from the University of Houston-Clear Lake in 1986.

Harbaugh came to NASA upon his graduation from Purdue and served in engineering and management positions at JSC until his selection as an astronaut. Harbaugh supported Shuttle operations in Mission Control for most flights from STS-1 through STS-51L, working as a Data Processing Systems (DPS) flight controller and later as a Shuttle Planning and Analysis Manager, the senior flight controller interface with the engineering community. He also has a commercial pilot's license and has logged more than 1,000 hours flying time.

**Donald R. McMonagle, 38, Lt. Col., USAF,** will serve as Mission Specialist 2 (MS2). Selected as an astronaut in 1987, he was born in Flint, Mich., and will make his first space flight.

McMonagle graduated from Hamady High School, Flint, Mich., in 1970; received a bachelor of science in aeronautical engineering from the Air Force Academy in 1974; and a master of science in mechanical engineering from California State University-Fresno in 1985.

He completed pilot training on the F-4 in 1975 and was assigned a year-long tour of duty at Kunsan Air Base, South Korea. He returned to Holloman AFB, N.M., in 1977 for training on the F-15, and, in 1979, was assigned as an F-15 instructor at Luke AFB, Ariz. In 1981, he attended the Air Force Test Pilot School and graduated as the outstanding pilot of his class. From 1982-1985, he was the operations officer and test pilot for the Advanced Fighter Technology Integration (AFTI) F-16. He then attended the Air Command and Staff College at Maxwell AFB, Ala., for 1 year before being assigned as operations officer for the 6513th Test Squadron at

Edwards AFB, Calif., where he was stationed at the time of his selection by NASA.

McMonagle has logged more than 3,400 hours flying time in a variety of aircraft.

**Guion S. Bluford**, 48, Col., USAF, will serve as Mission Specialist 3 (MS3). Selected as an astronaut in 1979, Bluford was born in Philadelphia, Pa., and will make his third space flight.

Bluford graduated from Overbrook High School, Philadelphia, in 1960; received a bachelor of science in aerospace engineering from Pennsylvania State University in 1964; received a master of science in the same subject from the Air Force Institute of Technology in 1974; received a doctorate in aerospace engineering with a minor in laser physics from the Air Force Institute of Technology in 1978; and received a master of business administration from the University of Houston-Clear Lake in 1987.

He served as a mission specialist on STS-8, launched Aug. 30, 1983, the third flight of Challenger and first mission with a night launch and landing. During the flight, the crew deployed the Indian National Satellite (INSAT-1B) and operated the remote manipulator system with a test article. His next flight was as a mission specialist aboard Challenger on STS 61-A, launched Oct. 30, 1985, with the German D-1 Spacelab.

Bluford has logged more than 314 hours in space.

**C. Lacy Veach**, 46, will serve as Mission Specialist 4 (MS4). Selected as an astronaut in 1984, Veach considers Honolulu his hometown and will make his first space flight.

Veach graduated from Punahou School in 1962 and received a bachelor of science in engineering management from the Air Force Academy in 1966.

Veach was commissioned in the Air Force upon graduation from the Academy and received his pilot wings in 1967. For 14 years, he served as a fighter pilot with a variety of assignments in the United States and overseas, including a 275-mission combat tour in Southeast Asia and 2 years with the Air Force Demonstration Squadron, the Thunderbirds. Veach left active duty in 1981, but continues to fly with the Texas Air National Guard.

He began work at NASA in 1982 as an engineer and research pilot, serving as an instructor pilot in the Shuttle Training Aircraft until his selection as an astronaut.

He has logged more than 4,500 flying hours.

**Richard J. Hieb**, 35, will serve as Mission Specialist 5 (MS5). Selected as an astronaut in 1986, he considers Jamestown, N.D., his hometown and will make his first space flight.

Hieb graduated from Jamestown High School in 1973; received a bachelor of arts in math and physics from Northwest Nazarene College in 1977; and received a master of science in aerospace engineering from the University of Colorado in 1979.

Hieb began work for NASA after graduating from the University of Colorado, serving in the crew procedures development and crew activity planning areas. He worked in Mission Control for ascent during STS-1 and specialized in rendezvous and proximity operations for numerous subsequent flights.

# **NASA SPACE SHUTTLE MANAGEMENT**

## **NASA Headquarters Office of Space Flight Washington, D.C.**

Dr. William B. Lenoir - Associate Administrator  
Robert L. Crippen - Director, Space Shuttle  
Leonard S. Nicholson - Deputy Director, Space Shuttle (Program)  
Brewster Shaw - Deputy Director, Space Shuttle (Operations)

## **Kennedy Space Center Kennedy Space Center, Fla.**

Forrest S. McCartney - Director  
Jay Honeycutt - Director, Shuttle Management & Operations  
Robert B. Sieck - Launch Director  
John T. Conway - Director, Payload Management & Operations  
Joanne H. Morgan - Director, Payload Project Management  
Roelf Schuiling - STS-39 Payload Manager

## **Marshall Space Flight Center Huntsville, Ala.**

Thomas J. Lee - Director  
Dr. J. Wayne Little - Deputy Director  
G. Porter Bridwell - Manager, Shuttle Projects Office  
Dr. George F. McDonough - Director, Science and Engineering  
Alexander A. McCool - Director, Safety and Mission Assurance  
Victor Keith Henson - Manager, Solid Rocket Motor Project  
Cary H. Rutland - Manager, Solid Rocket Booster Project  
Jerry W. Smelser - Manager, Space Shuttle Main Engine Project  
Gerald C. Ladner - Manager, External Tank Project

**Johnson Space Center  
Houston, TEXAS**

Aaron Cohen - Director  
Eugene F. Kranz - Director, Mission Operations  
Franklin Brizzolara - Payload Integration Manger

**Stennis Space Center  
Bay St. Louis, Miss.**

John S. Estess - Director  
Gerald W. Smith - Deputy Director  
J. Harry Guin - Director, Propulsion Test Operations

**Ames-Dryden Flight Research Facility  
Edwards, Calif.**

Kenneth J. Szalai, Director  
T.G. Ayers, Deputy Director  
James R. Phelps, Chief, Shuttle Support Office

# Department of Defense Payload Management

## Key Management Participants

Martin C. Faga - Assistant Secretary of the Air Force for Space

### Mission Directors

Lt. Gen. Donald L. Cromer - Commander, Space Systems Division

Col. John E. Armstrong - Program Manager, Space Test and Transportation System Office

### CARGO Operations Officers

Maj. Robert Crombie - SSD/CLPC

Capt. Linda Wolters - SSD/CLPC

### IBSS Program Directors

Mike Harrison - SDIO/TNS

Howard Stears - SKW Corp.

### AFP-675 Program Directors

Capt. Lindley Johnson - SSD/CLPC

Capt. Lloyd Johnson - SSD/CLPC

### STP-1 Program Directors

Ted Goldsmith - GSFC

Capt. Hau Tran - SSD/CLPC

## **Key Operations Participants**

### **IBSS Operations Directors**

Capt. Al Locker - GL  
1Lt. Ross Balestreri - SSD/CLPC

### **IBSS Test Conductors**

Jim Covington - Aerospace  
Scott Bartell - SKW Corp.

### **IBSS Replanners**

Howard R. Pedolsky - Orbital Systems, Ltd.  
Larry Sharp - Aerospace

### **AFP-675 Operations Directors**

Capt. Mike Spencer - SSD/CLPC  
Capt. Pete Clarke - SSD/CLPC

### **STP-1 Operations Directors**

Debbie Knapp - GSFC  
Vic Gehr - GSFC



# Upcoming Space Shuttle Flights

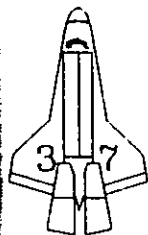

## Atlantis

1991  
Pad 39-B

Targeted for launch in April. Gamma Ray Observatory to be deployed in orbit. 28.5 degrees inclination/280 st. miles. Five days. Crew: Steven R. Nagel; Kenneth D. Cameron; Jerome Apt; Linda M. Godwin; Jerry L. Ross.

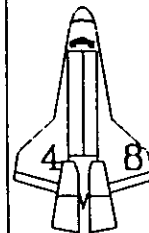

## Discovery

1991  
Pad 39-A

Launch targeted for November. Upper Atmosphere Research Satellite to be deployed. 57 degrees inclination/330 st. miles. Ten days. Crew: John O. Creighton; Kenneth S. Reightler; James F. Buchli; Mark N. Brown; Charles D. "Sam" Gernar.

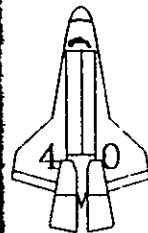

## Columbia

1991  
Pad 39-A

Targeted for launch in May. SLS-01 (Space Life Sciences Laboratory) 39 degrees inclination/184 st. miles. Nine days. Crew: Bryan D. O'Connor; Sidney M. Gutierrez; M. Rhea Seddon; James P. Bagian; Tamara E. Jernigan; F. Drew Gaffney; Millie Hughes-Fulford.

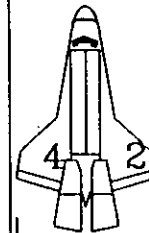

## Atlantis

1991  
Pad 39-B

Launch targeted for December. Payload is International Microgravity Laboratory-01 housed in a Spacelab long module. 28.5 degrees inclination/192 st. miles. Seven days. Crew: R. J. Grabe; S. S. Oswald; M. L. Carter; N. E. Thagard; Wm. F. Readdy; Ulf Merbold; Roberta L. Bondar.

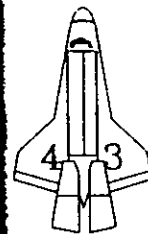

## Discovery

1991  
Pad 39-A

Targeted for launch in July. TDRS-E communications satellite to be placed in stationary orbit. 28.5 degrees inclination/184 st. miles. Nine days. Crew: John E. Blaha; Michael A. Baker; James C. Adamson; G. David Low; Shannon W. Lucid.

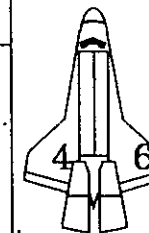

## Discovery

1992  
Pad 39-A

Launch targeted for March. Tethered Satellite System-01, EURECA (European Retrievable Carrier). 28.5 degrees inclination/265 st. miles. Seven days. Crew includes Loren Shriver; James D. Wetherbee; Andrew M. Allen; F. R. Chang-Diaz; J. A. Hoffman; Claude Nicollier; one PS TBD.

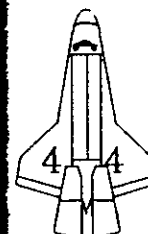

## Atlantis

1991  
Pad 39-A

Launch targeted for August. Defense Support Program satellite to be deployed. Cargo includes other DOD payloads. 28.5 degrees inclination/225 st. miles. Ten days. Crew: Frederick D. Gregory; Terence T. Henricks; F. Story Musgrave; Mario Runco Jr.; James S. Voss. One PS TBD.

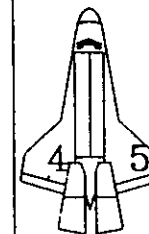

## Atlantis

1992  
Pad 39-A

Launch targeted for April. Atlas-01/SSBUV with igloo/2 pallets. 57 degrees inclination/184 st. miles. Seven days. Crew includes Charles F. Bolden; Brian Duffy; Kathryn D. Sullivan; C. Michael Foale; David C. Leestma; Michael L. Lampton; Byron K. Lichtenberg.

**SOME NOTES ON THIS SCHEDULE.** This is an unofficial Space Shuttle launch listing from April 1991 through April 1992. It is based on the manifest of Dec. 1990. Crew listings name commanders first, then pilots, then mission and payload specialists. The KSC Public Information Office at Area Code 407/867-2468 is your contact for additional information. Exact launch dates will be established at the Flight Readiness Reviews held prior to each mission.

Graph dated Jan. 17, 1991

# SHUTTLE FLIGHTS AS OF DECEMBER 1990

38 TOTAL FLIGHTS OF THE SHUTTLE SYSTEM  
13 MISSIONS CONDUCTED SINCE RETURN TO FLIGHT

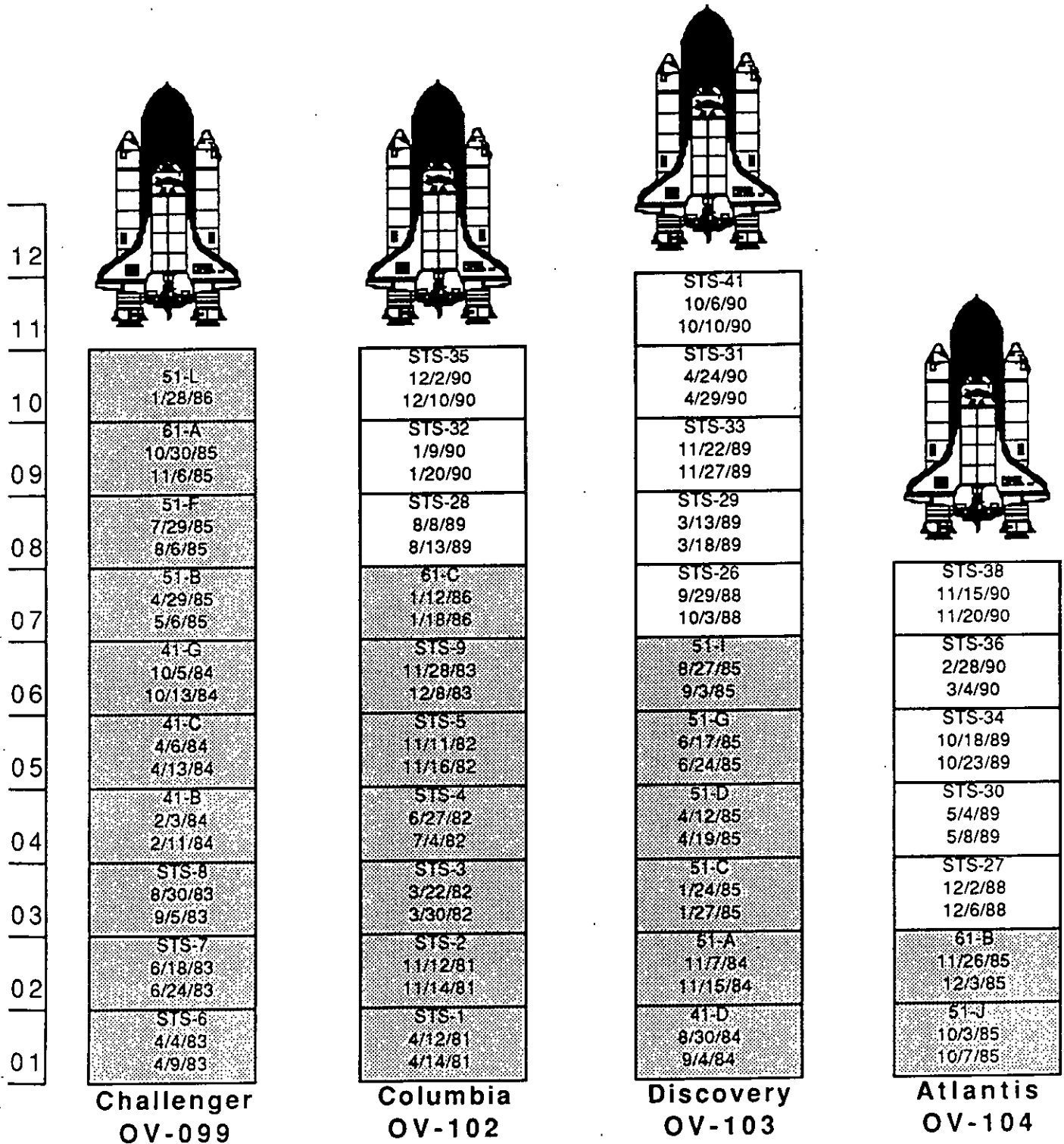



**SSP INTEGRATION  
AND OPERATIONS**

**CUSTOMER INTEGRATION OFFICE**

---

# **STS-39 Payload Information Document**

NOT FOR RELEASE TO THE PUBLIC

STS-39 PID



National Aeronautics and  
Space Administration  
Washington, D.C.  
20546

JAN 18 1991

Reply to Attn of.

JSC, TC12-91-001

TO: Distribution  
FROM: TA/Manager, Space Shuttle Integration and Operations  
SUBJECT: Transmittal of the STS-39 Payload Information Document

The STS-39 Payload Information Document (PID) is enclosed for your information.

The PID is a summary of the descriptions, purposes, operations, and flight histories of the STS-39 payloads, and is designed to be used for information only.

  
H.C. Harold Lambert, Jr.

Enclosure

Distribution:  
Payload Information Document Standard Distribution



**SSP** INTEGRATION  
AND OPERATIONS

**CUSTOMER INTEGRATION OFFICE**

---

# **STS-39**

# **Payload Information Document**

NOT FOR RELEASE TO THE PUBLIC

STS-39 PID



**SSP** INTEGRATION  
AND OPERATIONS

## **STS-39 PAYLOAD INFORMATION DOCUMENT**

---

### **PURPOSE**

**To summarize the descriptions, purposes, operations, and flight histories of STS-39 payloads.**



**SSP** INTEGRATION  
AND OPERATIONS

# STS-39 PAYLOAD INFORMATION DOCUMENT

## STS-39 CARGO CONFIGURATION

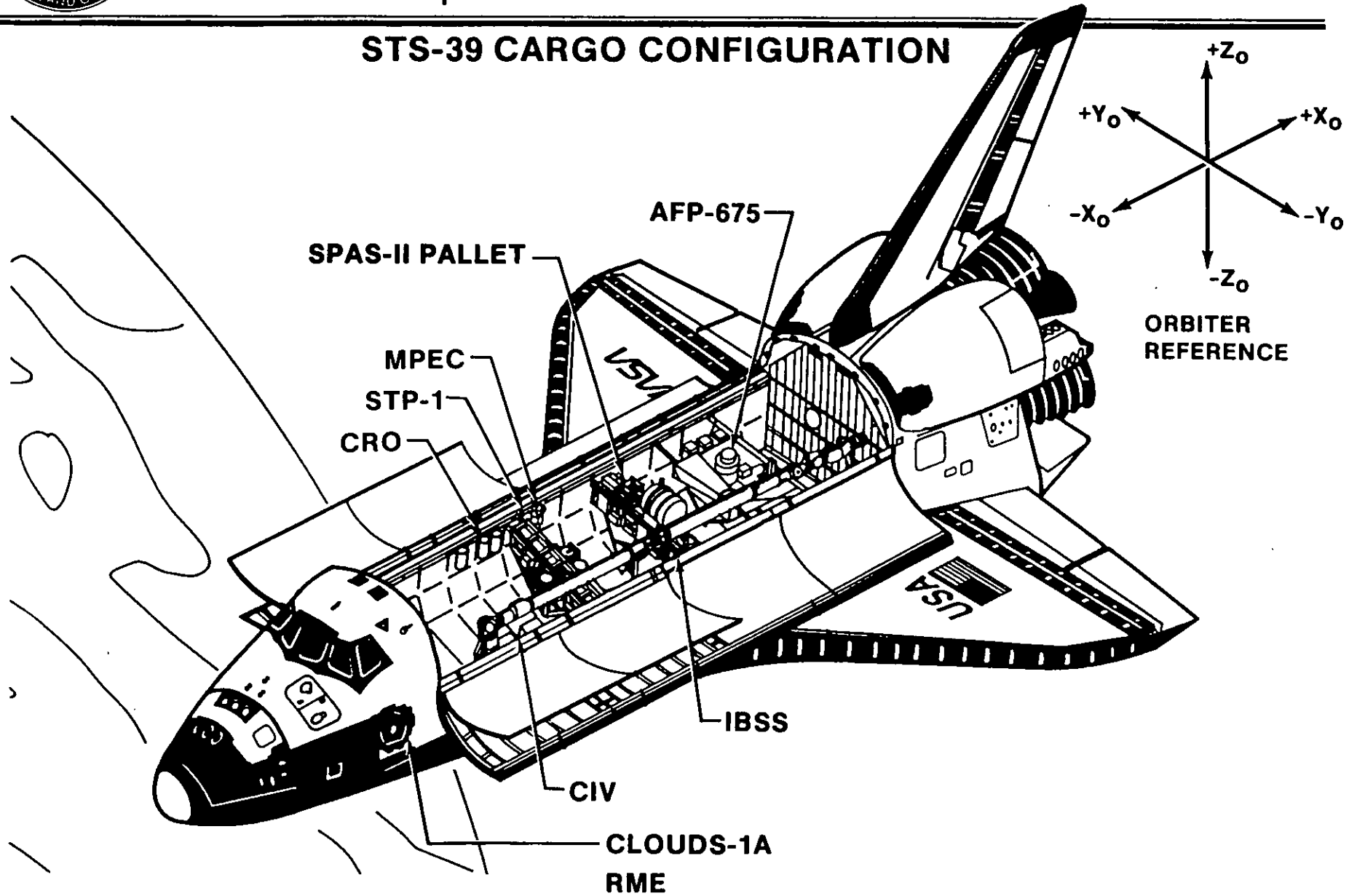



**SSP** INTEGRATION  
AND OPERATIONS

## **STS-39 PAYLOAD INFORMATION DOCUMENT**

---

### **STS-39 MANIFEST**

#### **● PAYLOAD BAY PAYLOADS**

- **Air Force Program - 675/Cryogenic Infrared Radiance Instrumentation for Shuttle (AFP-675/CIRRIIS)**
- **Infrared Background Signature Survey (IBSS)**
  - **Shuttle Pallet Satellite II (SPAS-II)**
  - **Chemical Release Observation (CRO)**
  - **Critical Ionization Velocity (CIV)**
- **Multipurpose Experiment Canister (MPEC)**
- **Space Test Program 1 (STP-1)**
  - **Advanced Liquid Feed Experiment (ALFE)**
  - **Ascent Particle Monitor (APM)**
  - **Data System Experiment (DSE)**
  - **Spacecraft Kinetic Infrared Test (SKIRT)**
  - **Ultraviolet Limb Imaging Experiment (UVLIM)**

#### **● MIDDECK PAYLOADS**

- **Cloud Logic to Optimize Use of Defense Systems (CLOUDS-1A)**
- **Radiation Monitoring Equipment (RME)**



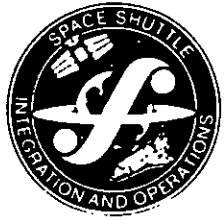

**SSP** INTEGRATION  
AND OPERATIONS

## **STS-39 PAYLOAD INFORMATION DOCUMENT**

---

# **Payload Bay Payloads**



---

## **AIR FORCE PROGRAM 675 (AFP-675)**

### **● DESCRIPTION**

The AFP-675 is an experiment support system (ESS) consisting of the space vehicle (SV) and five sensing instruments. The SV, a predominately self-contained integrated structure, remains attached to the Orbiter payload bay during the mission. Several Department of Defense (DOD) experiments and supporting avionics including command, telemetry/recording, and power distribution systems are included on the SV. The Command and Monitor Panel (CMP), mounted in the payload dedicated console on the Orbiter aft flight deck (AFD), controls the sensing instruments, monitors the AFP-675 SV performance, and initiates commanding sequences. The sensing instruments consist of: Cryogenic Infrared Radiance Instrumentation for Shuttle (CIRRIS), Far Ultraviolet (FAR UV) Cameras, Uniformly Redundant Array (URA), Horizon Ultraviolet Program (HUP), and the Quadrupole Ion and Neutral Spectrometer (QINMS). Two manual pointing controllers (MPC's) for CIRRIS and FAR UV, in conjunction with the three Orbiter closed circuit television (CCTV) monitors, control experiment pointing. The CIRRIS contains a cryostat dewar containing liquid helium for maintaining instrument sensor temperatures close to absolute zero (4 deg. K). Space Vehicle control weight: 9980 lb. Airborne support equipment control weight: 350 lb. Total control weight: 10,330 lb.



---

## **AFP-675 (CONT)**

### **● PURPOSE**

To analyze and record data relating to the near Earth space envelope and celestial targets. The specific objectives of each experiment are as follows:

- CIRRIS measures the spatial, spectral, and temporal variations of the Earthlimb and aurora in the infrared spectrum from 2.5 to 25 micrometers in wavelength.
- FAR UV cameras are designed to photograph near-Earth and celestial ultraviolet (UV) sources, including airglow, aurora, stars, nebulae, galaxies and Orbiter surface glow. FAR UV cameras are also designed to photograph primary thruster firings and targets of opportunity.
- The URA demonstrates coded aperture imaging of x-ray emissions of celestial targets within a specified range.
- The HUP measures spatial and spectral ultraviolet characteristics of the Earth's horizon within a specified range.
- The QINMS monitors the contamination environment of the Orbiter. The measurements obtained from QINMS will be used as an input to the CIRRIS experiment to determine if the Orbiter environment is clean enough to operate CIRRIS.

**Customer: USAF Space Systems Division.**

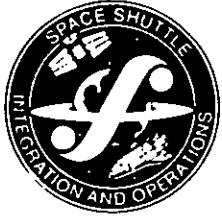

---

## **AFP 675 (CONT)**

### **● OPERATION**

The AFP-675 tape recorders will be powered on during countdown at approximately L-10 minutes. During ascent the tape recorders will remain powered up and the experiments will be powered off. Upon attaining orbit, the Orbiter payload bay doors are opened, the SV is powered up and checked out, and the Orbiter and SV will be allowed time to outgas in order to reduce instrument contamination. The AFP-675 experiments are designed to be operated by mission specialists from the AFD, utilizing the CMP. Manual pointing controllers (MPC's) located on the CMP are used to gimbal the CIRRIS and FAR UV experiments. Throughout the mission, the crew is required to maneuver the Orbiter to a variety of attitudes to observe celestial and Earthlimb targets. Crewmembers use the Payload and General Support Computer (PGSC) to calculate and display payload targeting information. One or two crewmembers are required to perform experiment operations. All measured data will be recorded onboard the AFP-675 SV and examined postflight.

### **● NO PREVIOUS FLIGHTS**



**SSP** INTEGRATION  
AND OPERATIONS

# STS-39 PAYLOAD INFORMATION DOCUMENT

## AFP-675 SPACE VEHICLE CONFIGURATION

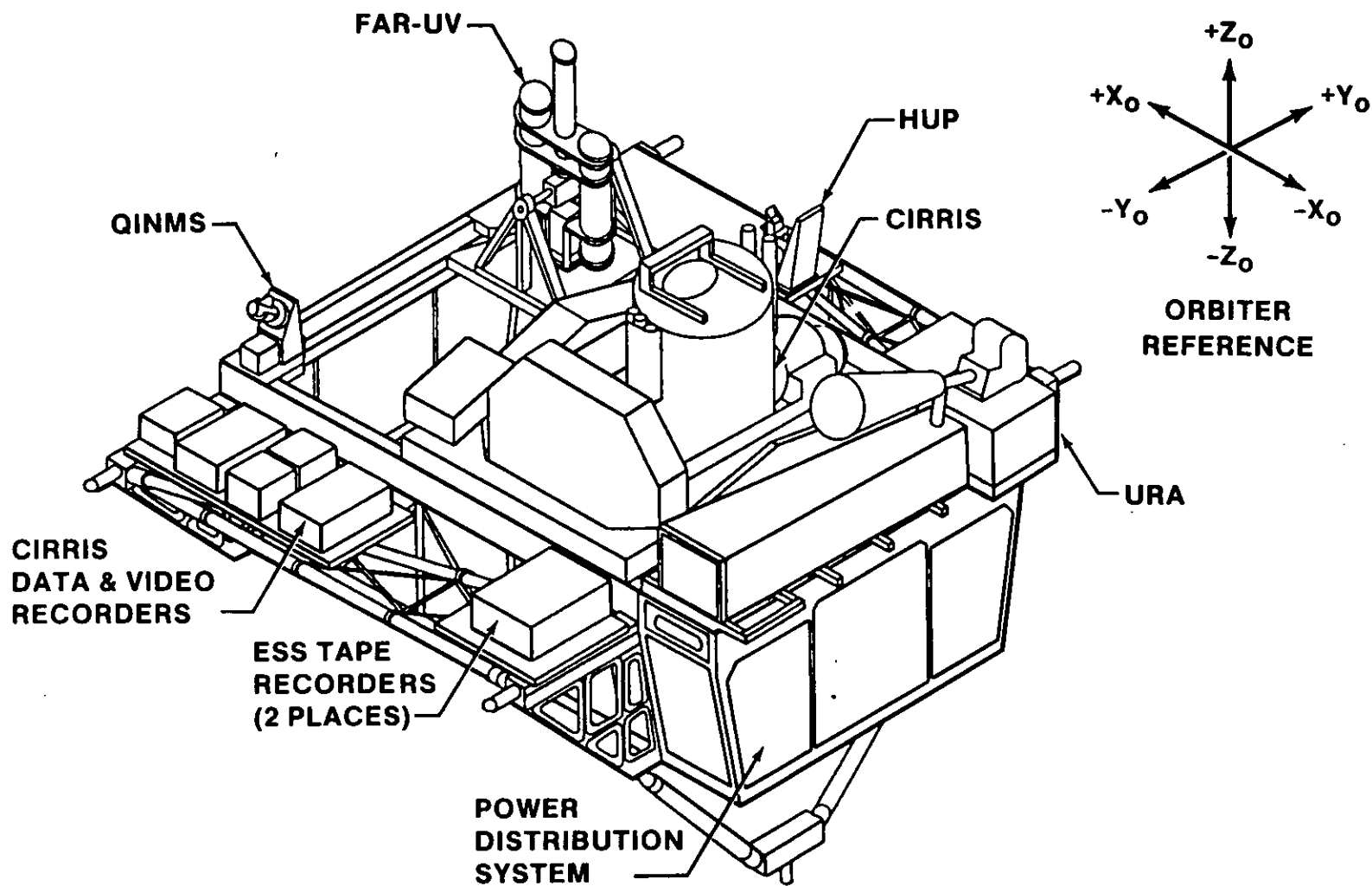



**SSP** INTEGRATION  
AND OPERATIONS

# STS-39 PAYLOAD INFORMATION DOCUMENT

## AFP-675 COMMAND AND MONITOR PANEL

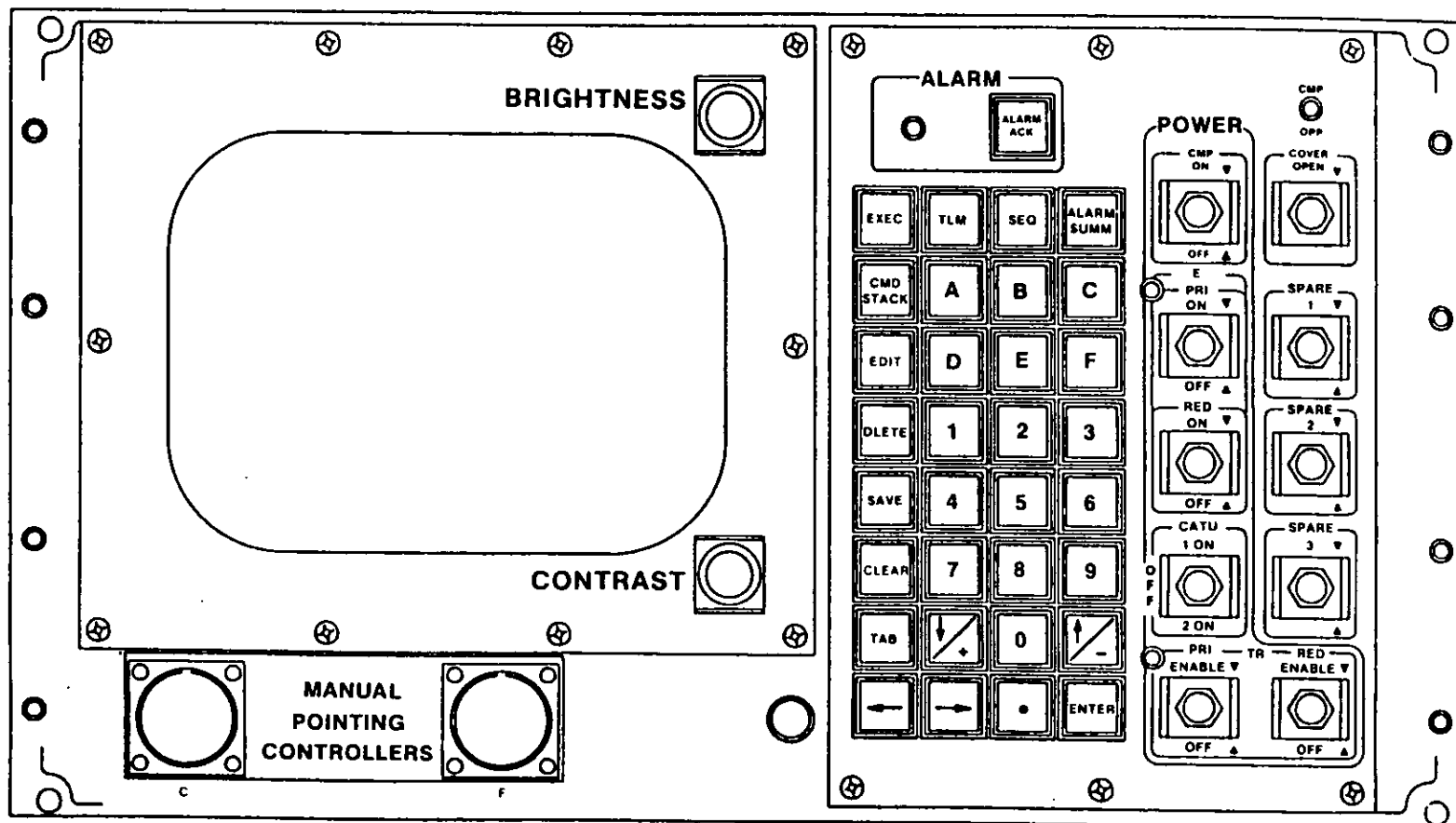



**MANUAL POINTING CONTROLLER (MPC)**

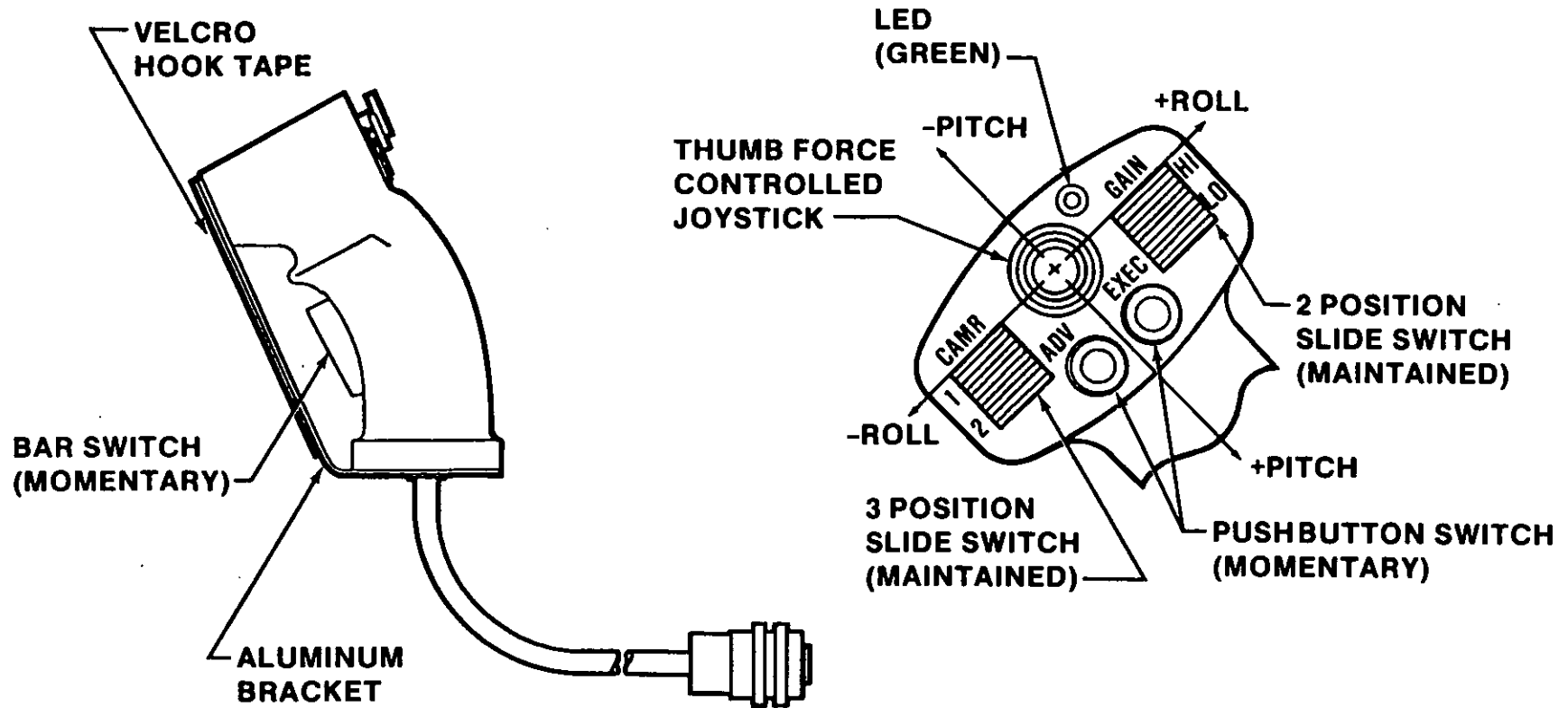



**SSP INTEGRATION  
AND OPERATIONS**

# STS-39 PAYLOAD INFORMATION DOCUMENT

## CIRRIS EXPERIMENT CONFIGURATION

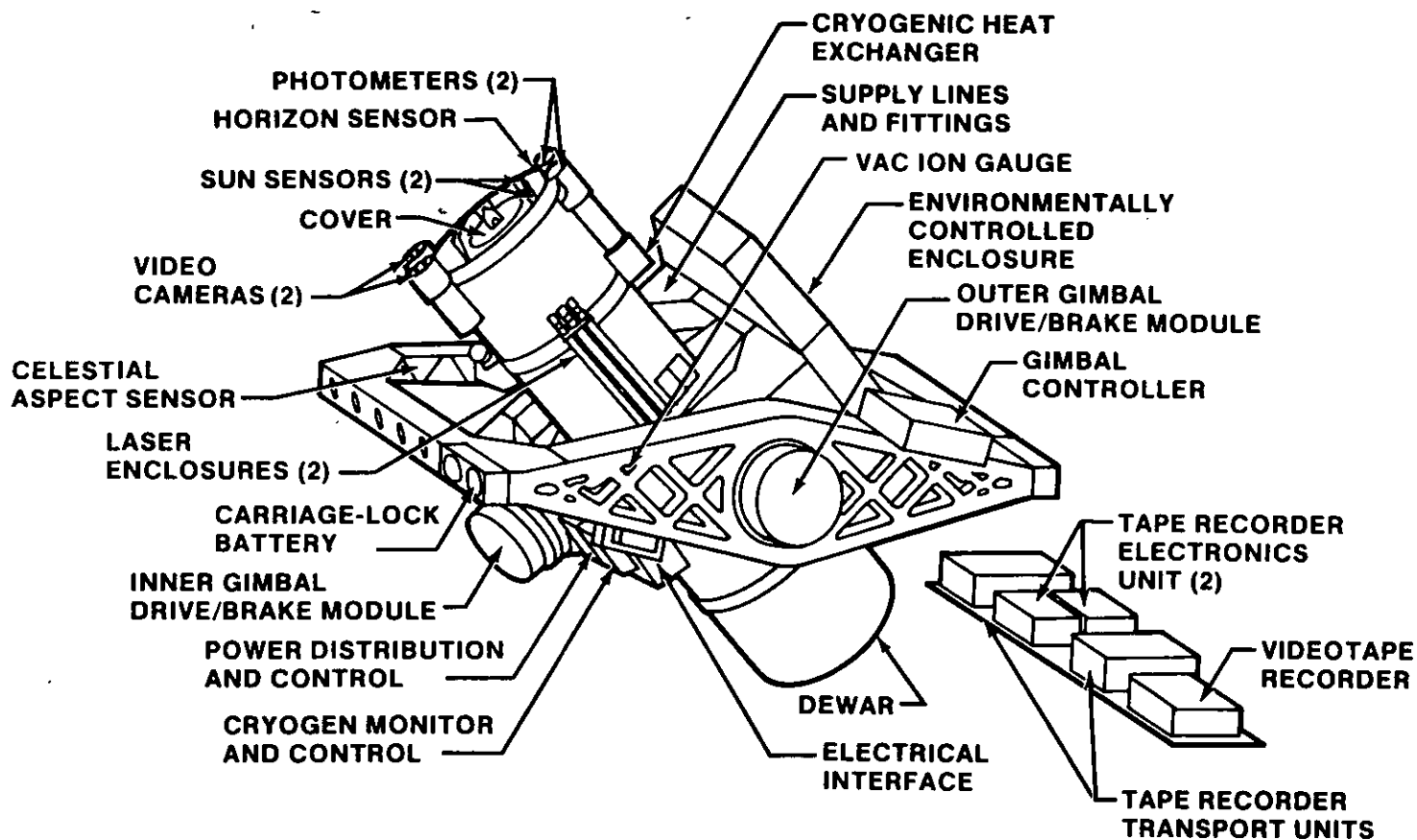





**FAR UV INSTRUMENT**

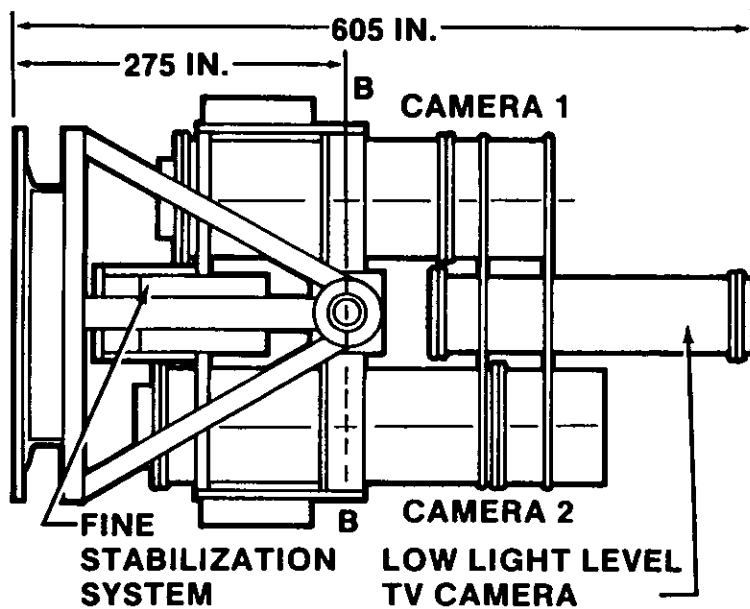

**ACROSS-BAY VIEW**

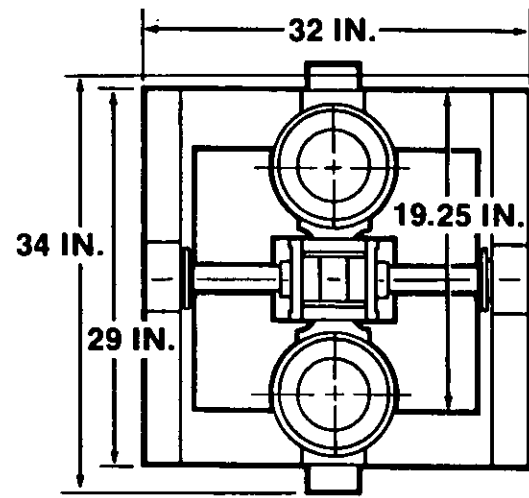

**TOP VIEW  
(LESS TV CAMERA)**

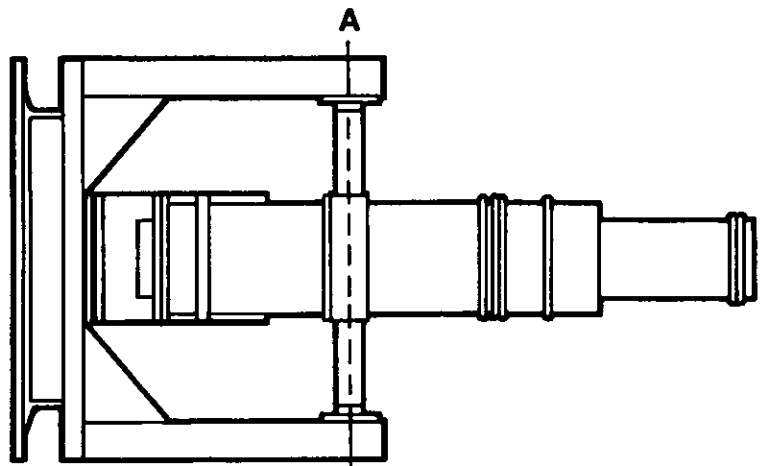

**ALONG-BAY VIEW**



**SSP INTEGRATION  
AND OPERATIONS**

# STS-39 PAYLOAD INFORMATION DOCUMENT

## HUP INSTRUMENT

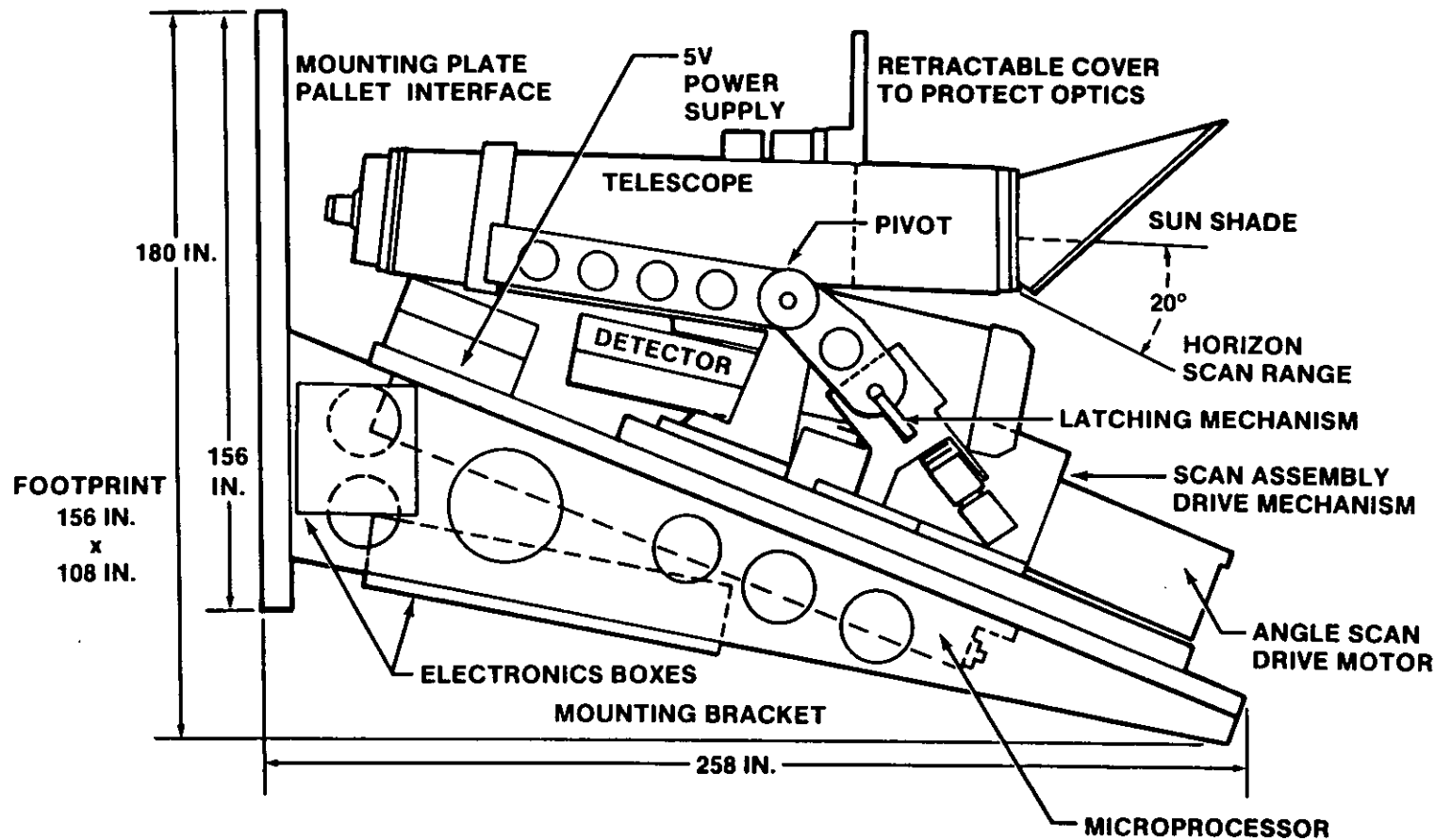



**QINMS EXPERIMENT CONFIGURATION**

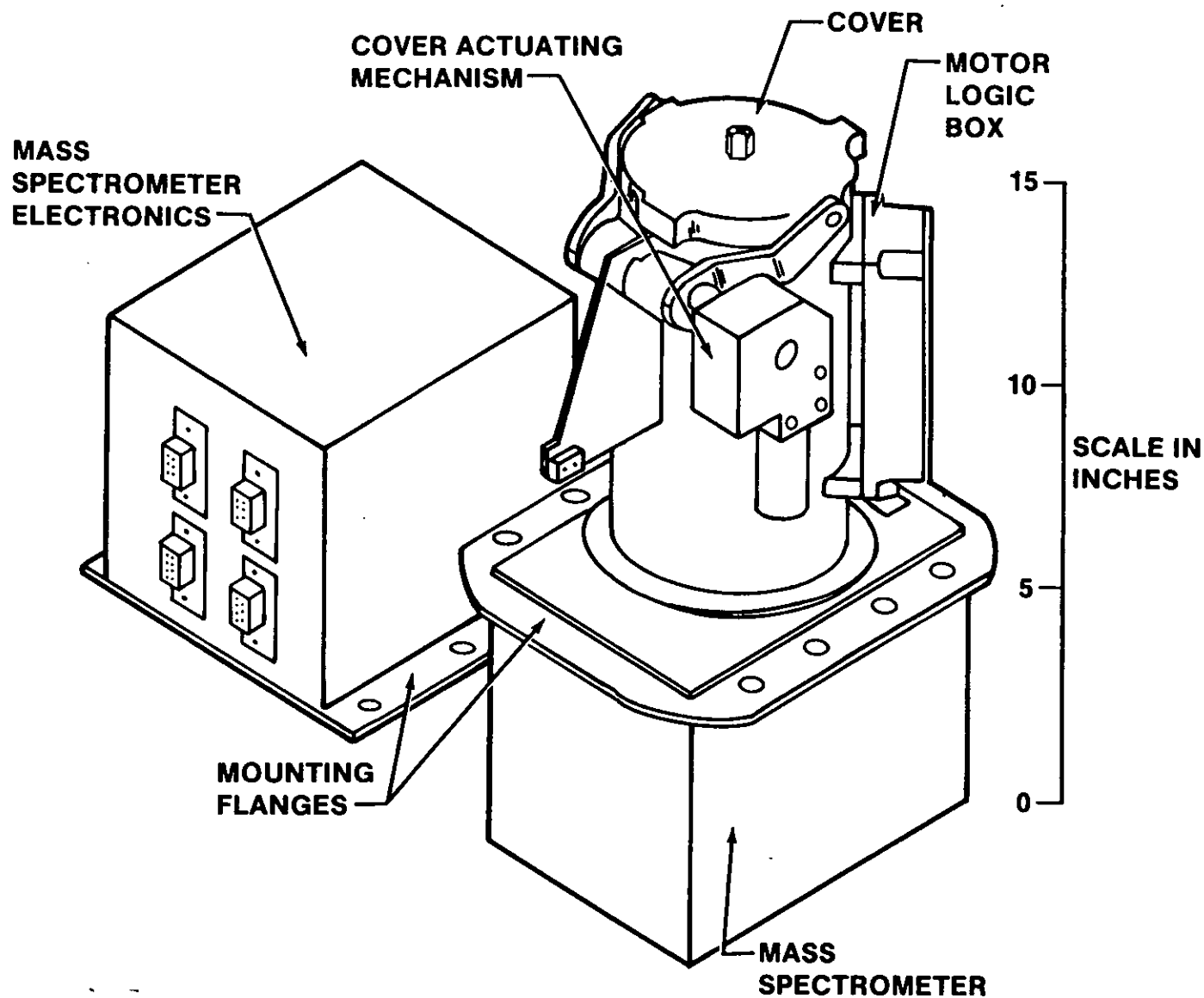



---

## **INFRARED BACKGROUND SIGNATURE SURVEY (IBSS)**

### **● DESCRIPTION**

The IBSS is a multiple sensor experiment mounted on the Shuttle Pallet Satellite (SPAS-II). It consists of an infrared radiometer and spectrometer mounted internally in a liquid helium cooled cryostat, a complex of multispectral sensors used to collect both spectral and spatial data, and two low light level television cameras to assist in pointing the pallet during deployed operations. The SPAS-II contains subsystems required to support operations of the payload, including batteries, power distribution, communications for data and commands, and attitude control. A remotely operated electrical umbilical (ROEU) provides the timing, commanding, telemetry, and power interface to the SPAS-II when it is berthed in the payload bay. Two longeron trunnions and one keel trunnion are the mechanical interfaces with the Orbiter. The remote manipulator system (RMS) performs deployment and retrieval functions of the SPAS-II. Two supplementary payload elements are the Critical Ionization Velocity (CIV) and the Chemical Release Observation (CRO). Four gas containers, a controller, and a sensor for the CIV experiment are mounted on two increased capacity adaptive payload carrier (ICAPC) beams. The CRO consists of three deployable subsatellites, each containing a different propellant. The CRO is attached in the payload bay on two Get Away Special (GAS) adapter beams. Total control weight: 5,681 lb. (excluding unique integration hardware).



---

## **IBSS (CONT)**

### **● PURPOSE**

To collect multispectral signatures from various natural and induced backgrounds including plumes generated by the orbital maneuvering system (OMS) and primary reaction control system (PRCS), the Earthlimb, chemicals released into space, the Earth, the Orbiter environment, and various calibration sources. Customer: Strategic Defense Initiative Organization and USAF Space Systems Division.

### **● OPERATION**

The SPAS-II will be operated 24 hours a day by flight crew and ground support personnel. There are three modes of operation: (1) payload bay; (2) free-flight; and (3) RMS attached. As soon as practical after orbital altitude is achieved, the Arizona Imager Spectrograph (AIS) will be activated via ground command for payload bay observation of Orbiter tail glow phenomena. During the 36-hour free-flight phase, several OMS and PRCS plume data takes, Chemical Release Observations (CRO's), Critical Ionization Velocity (CIV) gas plume effects, and Earthlimb and Earth scans will be performed. Following the second CRO observation during the rendezvous phase, the SPAS-II will be grappled by the RMS and berthed in the payload bay for approximately 2 days. The SPAS-II is then unberthed from the payload bay and additional observations are performed on the RMS.

During free-flight operations on flight day 3, plume data is collected at two different ranges, nearfield and farfield. The distance of separation between the Orbiter and the



---

## **IBSS (CONT)**

### **● OPERATION (CONT)**

SPAS-II is 1.4 (2.25 km) miles for nearfield and 6.2 (10 km) miles for farfield observations. Nearfield observations consist of 2 OMS burns. Farfield plume observations include 3 OMS burns and 1 PRCS firing. The single OMS engine firing is conducted with the OMS engine thrust vector control active and the PRCS enabled. The nominal first and second OMS firing observations are separated by a minimum of 6 hours to allow for payload assessment of data collected on the first plume observation.

Earthscan measurements are taken by observing the solar specular point (the point on Earth where the angle of incidence equals the angle of reflection) at a 24.9 mile altitude. Two types of scans, spectral and spatial, can be taken. Spectral scans use the infrared spectrometer, while spatial scans use the radiometer and are accomplished by the orbital motion of SPAS-II. Data for both types of scans is collected for four minutes on each side of either the sunrise or sunset terminator.

The CRO experiment employs three subsatellites (each with a different propellant) which are deployed from launchers in the Orbiter by a crewmember utilizing a small payload accommodation switch panel (SPASP) in the AFD. Observation of the subsatellite chemical release occurs at a 30 to 125 mile (50 to 200 km) distance between the subsatellite and the deployed SPAS-II. As the subsatellite passes within a 5 degree elevation angle of Vandenberg Air Force Base, ground commands are issued by a DOD ground station to



---

## **IBSS (CONT)**

### **● OPERATION (CONT)**

release the fluid. The resulting chemical cloud is observed by the deployed SPAS-II (two free flight and one while attached to the RMS) science instruments and by ground and airborne instruments.

The CIV experiment consists of four individual pressure vessels mounted in the payload bay on ICAPC adapter beams. When the Orbiter has achieved the required attitude, the crew will command the release of four nonhazardous gases contained in the CIV pressure vessels. The released gas is controlled by a crewmember using the standard switch panel in the AFD. Gas streams are ejected in the direction of the velocity vector to maximize the relative motion between the gas and free stream. The resultant gas plume effect is observed by deployed SPAS-II instruments. Observations are performed under varying light conditions and magnetic field orientations with respect to gas release direction. A recorder and a monitoring package located in separate containers collect data.

### **● NO PREVIOUS FLIGHTS**



**SSP INTEGRATION  
AND OPERATIONS**

# STS-39 PAYLOAD INFORMATION DOCUMENT

## SPAS-II PALLET (VIEW 1)

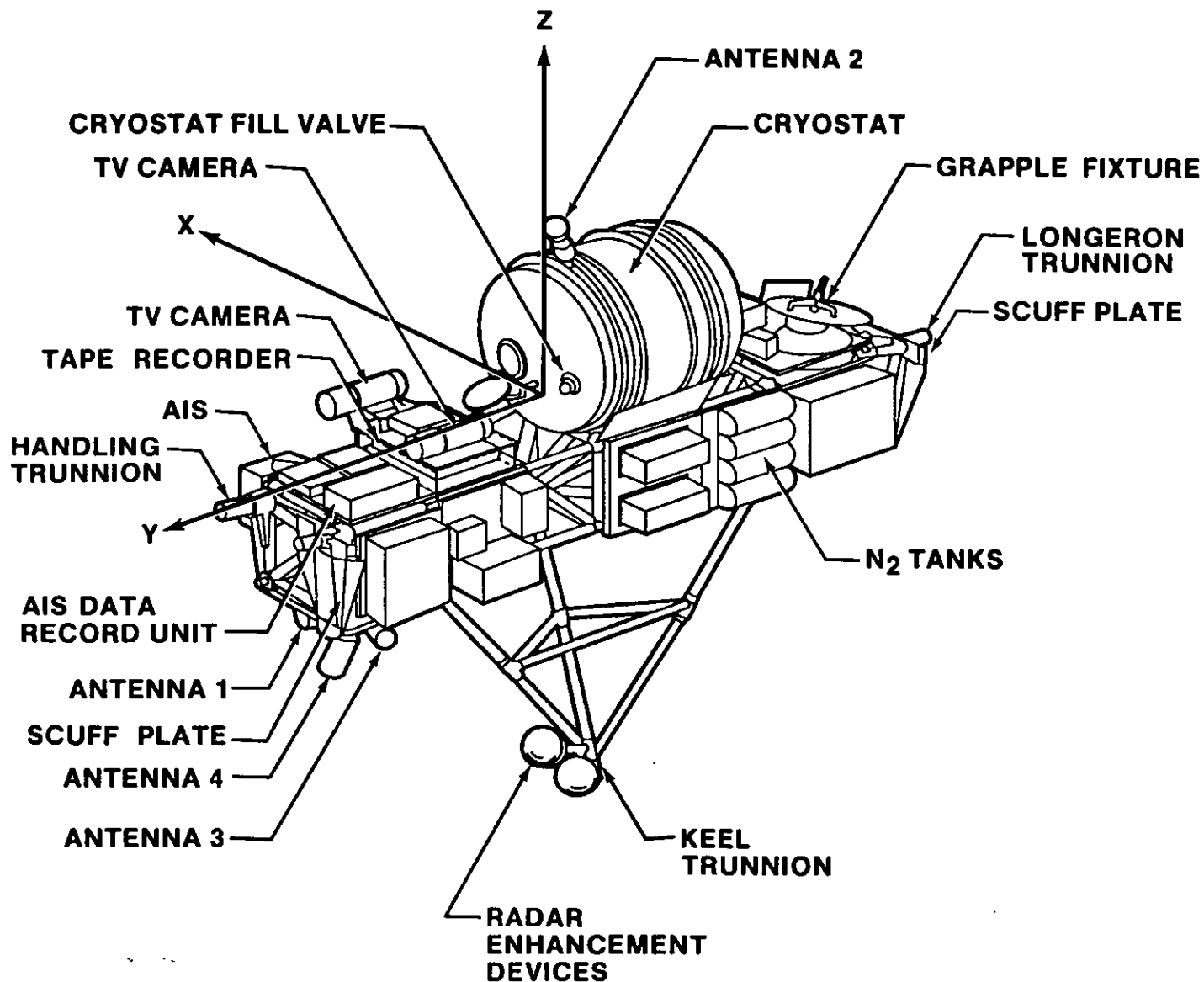



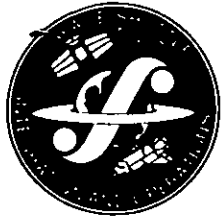

**SPAS-II PALLET (VIEW 2)**

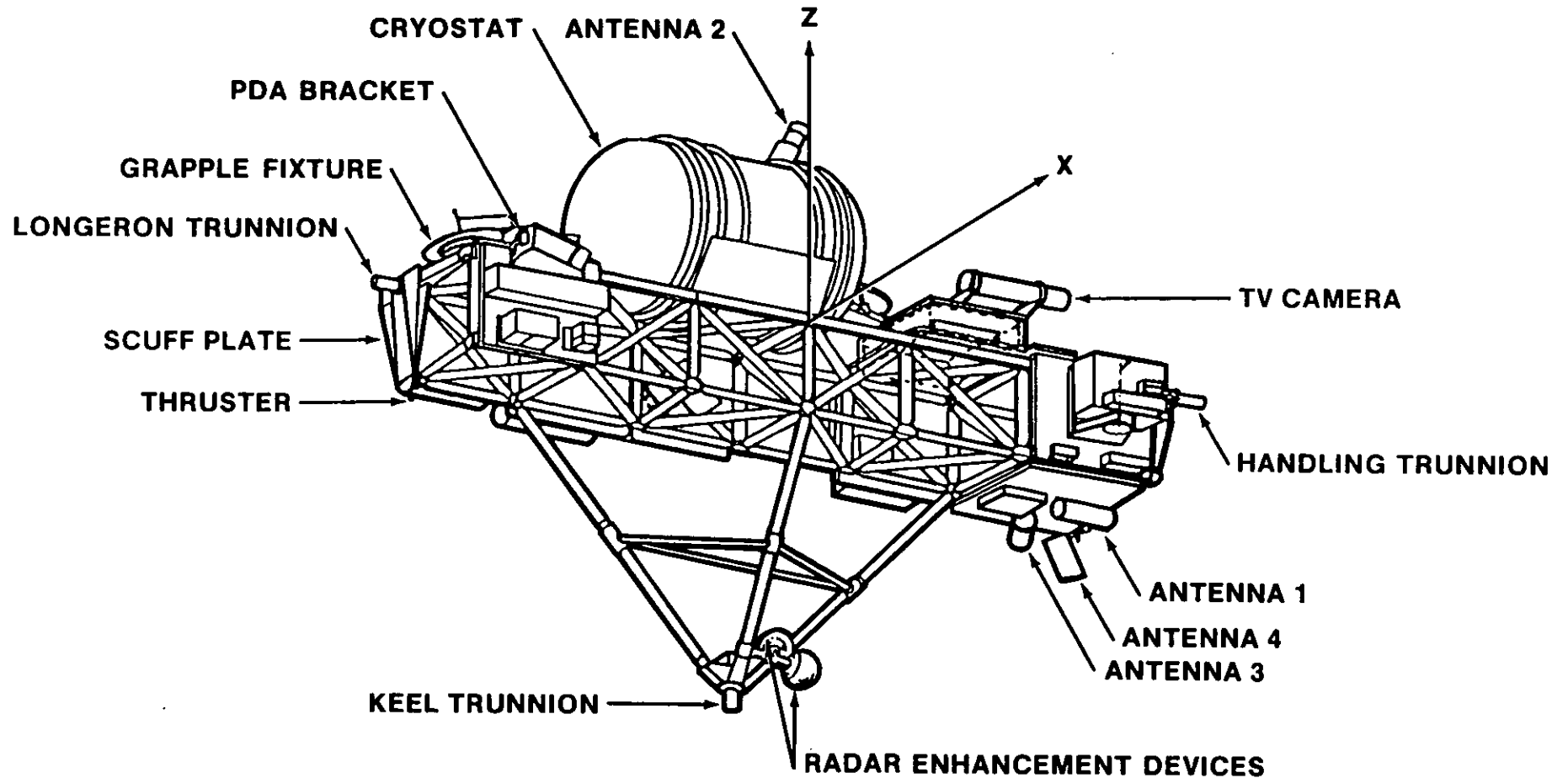



**CRO CONFIGURATION**

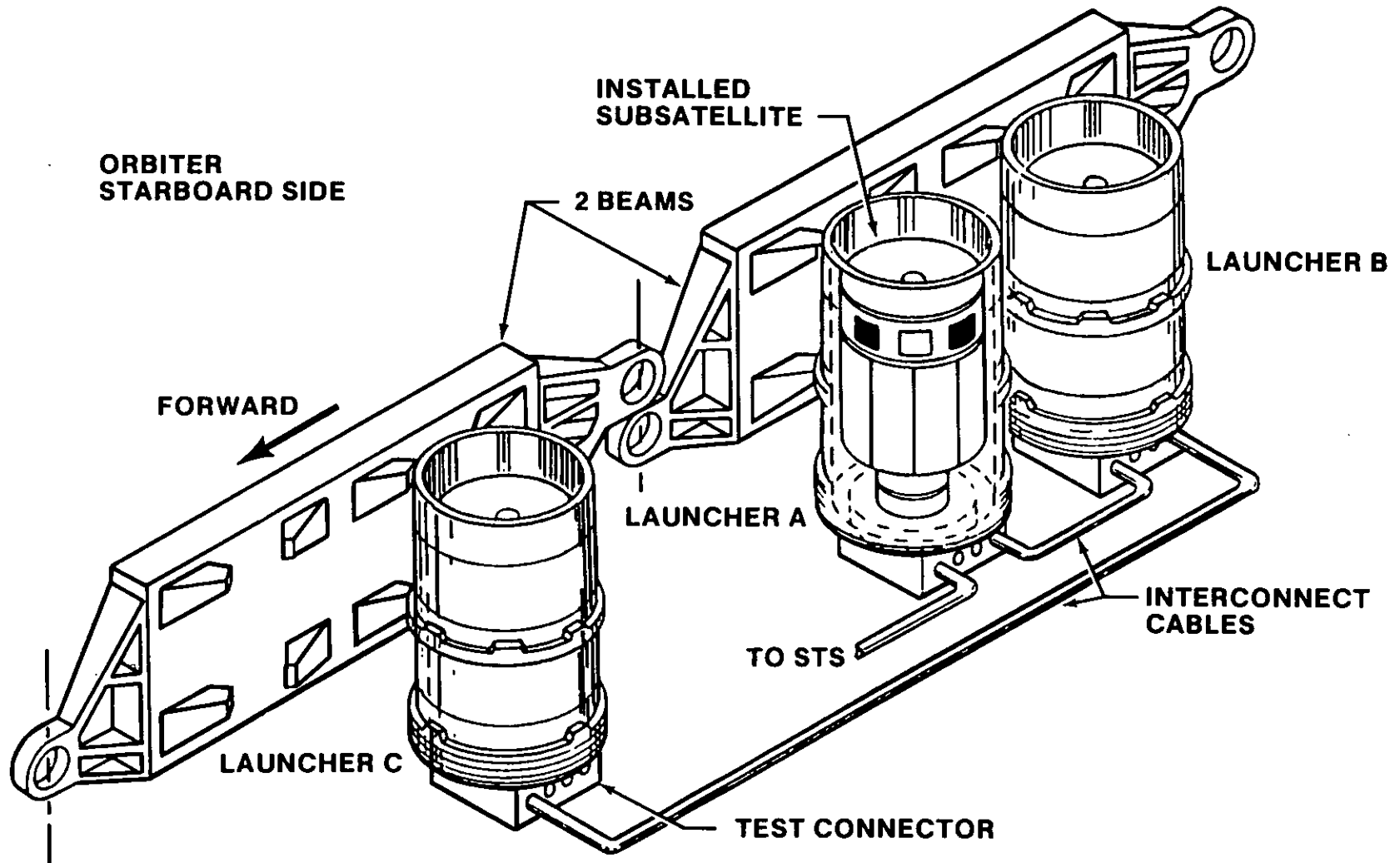



**CIV EXPERIMENT CONFIGURATION**

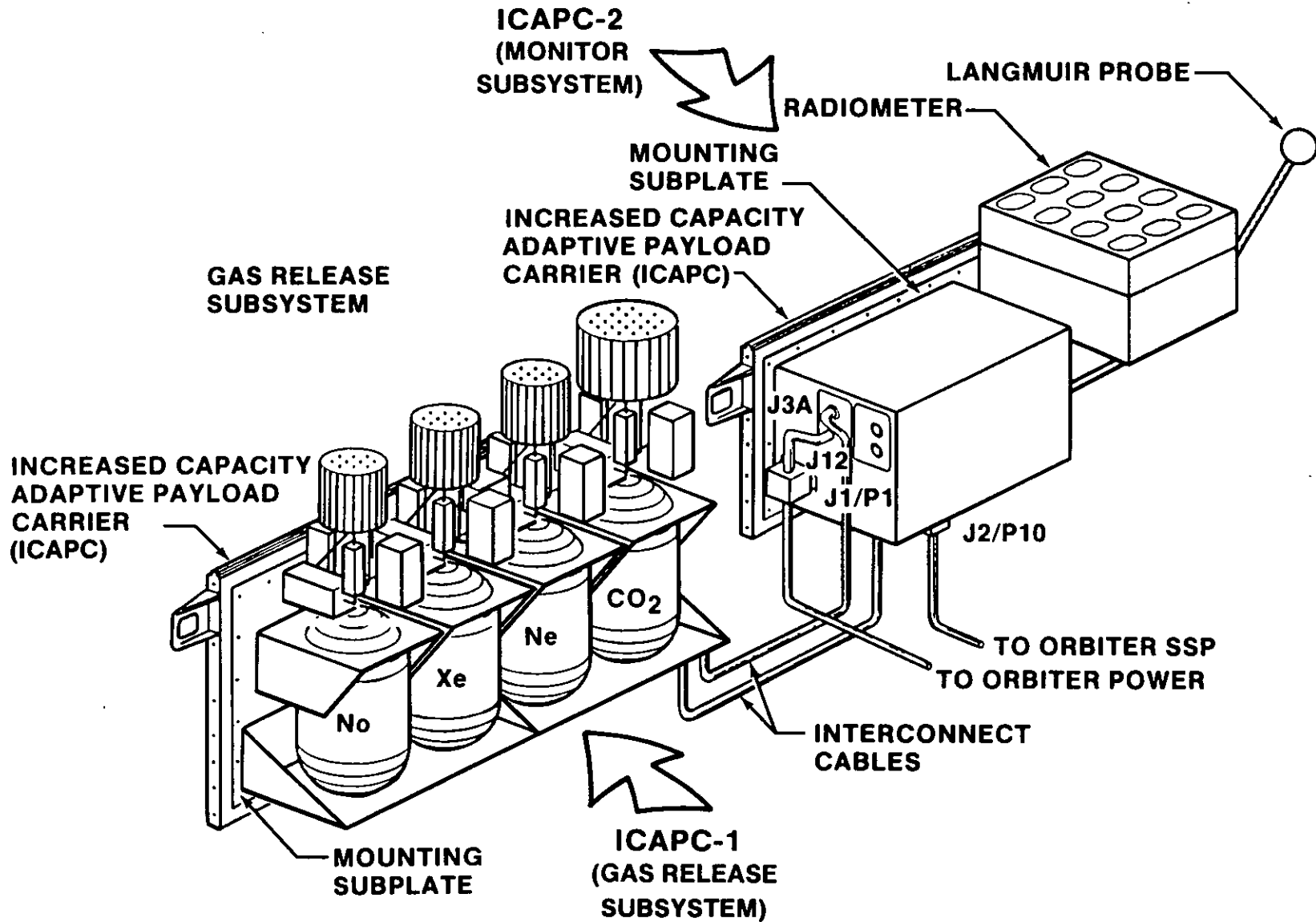



**SSP** INTEGRATION  
AND OPERATIONS

## **STS-39 PAYLOAD INFORMATION DOCUMENT**

---

### **MULTIPURPOSE EXPERIMENT CANISTER (MPEC)**

- **DESCRIPTION**

The MPEC payload consists of a modified Get Away Special (GAS) canister containing an ejectable experiment. The canister utilizes a 9-inch extension containing an ejector kit, electronic interfaces, and a full diameter motorized door assembly (FDMDA). Total control weight: 750 lb.

- **PURPOSE**

To eject the experiment contained in the MPEC canister. Customer: USAF Space Division.



---

## **MPEC (CONT)**

- **OPERATION**

Once in orbit the payload bay doors will be opened. Prior to payload activation, the hydraulic circulation pumps will be inhibited from the Orbiter bus providing power to the payload. The payload will be activated by the crew via switches on the standard switch panel. The standard switch panel has talkbacks that monitor operations and serve as an interface between the crew and the payload. NASA standard initiators (NSI's) are fired to release an explosive nut. The nut releases, causing the separation spring to move the push pad. The eight spring-loaded experiment retention pins retract. The push pad then contacts the bottom of the experiment and ejects it at about 2.7 ft/sec. Approximately 1 second elapses between the firing of the NSI's and separation from the canister. At ejection, a timer within the experiment begins. The experiment electronics are activated 45 minutes later. The FDMDA will then be closed and aft payload power removed. Total control weight: 750 lb.

- **NO PREVIOUS FLIGHTS**



**SSP** INTEGRATION  
AND OPERATIONS

## **STS-39 PAYLOAD INFORMATION DOCUMENT**

---

### **SPACE TEST PROGRAM 1 (STP-1)**

- **DESCRIPTION**

The Space Test Program 1 (STP-1) payload consists of five experiments, including instrument electronics and control systems mounted on a Hitchhiker-M bay carrier. The experiments are the Advanced Liquid Feed Experiment (ALFE), the Spacecraft Kinetic Infrared Test (SKIRT), Ultraviolet Limb Imaging Experiment (UVLIM), the Data System Experiment (DSE), and the Ascent Particle Monitor (APM). Total control weight: 4288 lb. Customer: USAF Space Systems Division and Goddard Space Flight Center.



**SSP** INTEGRATION  
AND OPERATIONS

# STS-39 PAYLOAD INFORMATION DOCUMENT

## STP-1 CONFIGURATION

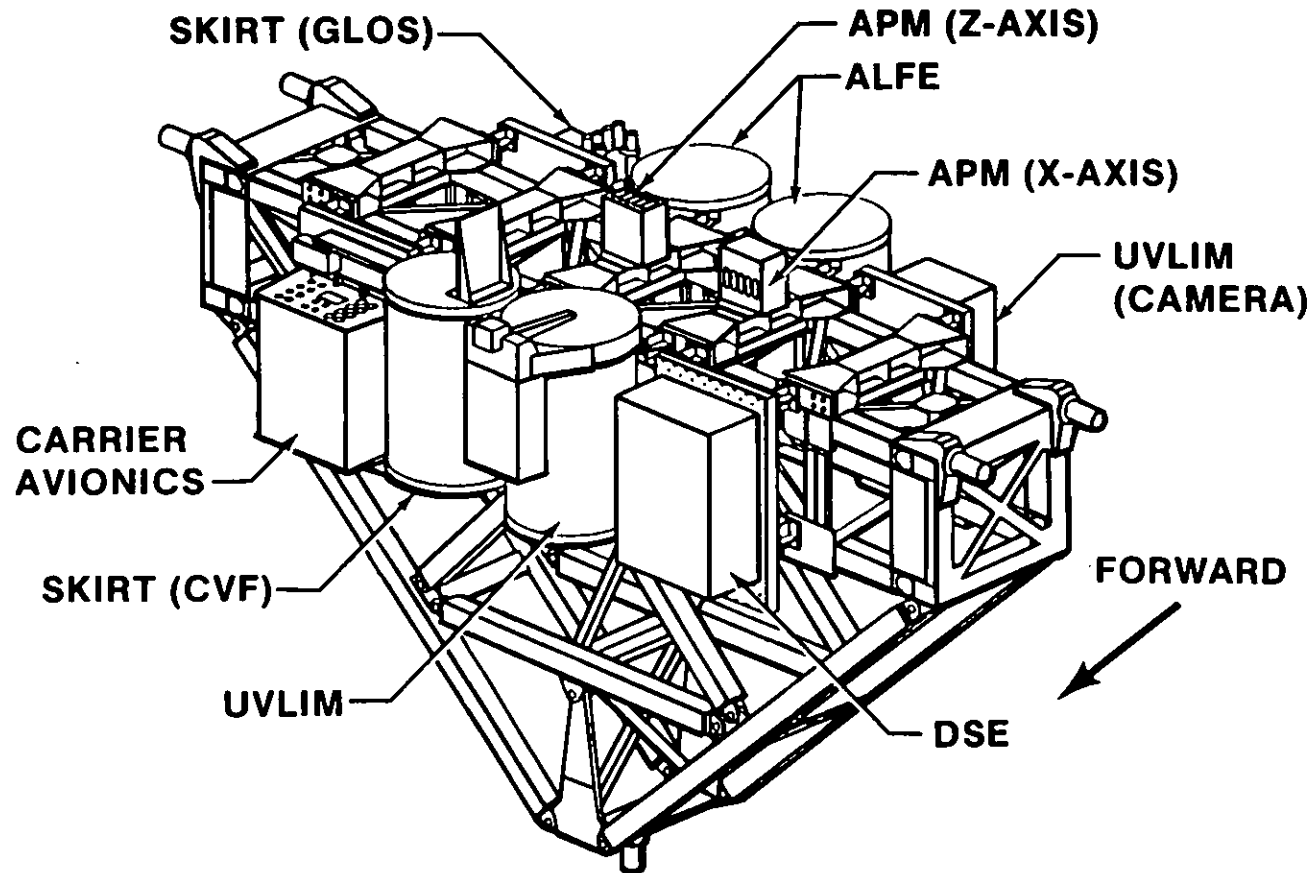



---

## **STP-1 ADVANCED LIQUID FEED EXPERIMENT (ALFE)**

### **● DESCRIPTION**

The ALFE consists of freon tanks, collection devices, a pump, an ultrasonic gauging system, valves, and a color TV camera housed in a Hitchhiker sealed canister. A separate interconnected sealed canister contains support electronics.

### **● PURPOSE**

To study the zero gravity performance of tanks and liquid collection systems and to evaluate propellant management system components under space flight environments.  
Sponsor: USAF Astronautics Laboratory.





---

## **STP-1 ALFE (CONT)**

- **OPERATION**

Following activation of heaters for the ALFE payload, the warm up period begins. Four phases of operation (A, B, C and D) are scheduled after the temperature reaches operational level (from 2.5 to 10 hours after activation). Each phase lasts for 30 minutes, and phase D is performed last. During phase C, the tanks are partially filled, data samples are verified, and a 60-second free drift period follows each burn execution. A minimum of 10 minutes must elapse between burns. Closed circuit television is required during all four phases.

- **NO PREVIOUS FLIGHTS**



---

## **STP-1 ASCENT PARTICLE MONITOR (APM)**

### **● DESCRIPTION**

The APM is a particle contamination and detachment experiment consisting of an aluminum housing mounting a clam shell arrangement of two material sample arrays called doors. The doors, one fixed and one movable, each contain six material sample coupons. Within the housing are the motor/gearbox assembly to operate the moving door; two battery packs to provide power; a launch detection circuit and microphone to sense Space Shuttle Main Engine (SSME) start; timer circuit door opening and closing circuitry; and redundant activation and deactivation microswitches. Two APM units are included on the STP-1 payload.

### **● PURPOSE**

To measure the particle activity in the payload bay during the immediate prelaunch period and ascent. Customer: USAF Space Systems Division.



---

## **STP-1 APM (CONT)**

- **OPERATION**

Two APM units will be attached to the top of the support structure to collect samples of particulate contamination during ascent. The APM's are self-contained and require no Orbiter services or crew support activity.

- **PREVIOUS FLIGHTS**

STS-28, STS-31.



---

## **STP-1 DATA SYSTEM EXPERIMENT (DSE)**

- **DESCRIPTION**

The DSE consists of a MILVAX computer, an erasable optical disk (EOD), and other data system elements. The DSE is self-contained and has no crew activity requirements.

- **PURPOSE**

To evaluate performance of the MILVAX computer and EOD system in a microgravity environment. Sponsor: Goddard Space Flight Center.

- **NO PREVIOUS FLIGHTS**



---

## **STP-1 SPACECRAFT KINETIC INFRARED TEST (SKIRT)**

- **DESCRIPTION**

The SKIRT experiment consists of a solid nitrogen-cooled infrared spectrometer housed in a sealed Hitchhiker canister with an aperture in the top plate. A glowplate attached to the top plate provides a surface for impingement of the residual atmosphere to produce the glow, which is then observed by the spectrometer. Additional ultraviolet (UV) and visible radiometers are mounted on a small external mounting plate. The SKIRT is composed of two operations: the Circular Variable Filter (CVF) and the Gaseous Luminosity of Optical Surfaces (GLOS).

- **PURPOSE**

To measure the atomic oxygen glow effect in visible, infrared, and ultraviolet spectra.  
Sponsor: USAF Geophysics Laboratory.



---

## **STP-1 SKIRT (CONT)**

- **OPERATION**

Both the CVF and GLOS operate throughout the mission in various attitudes. The SKIRT CVF operations are performed during a minimum of three night passes in an inertial attitude. The Orbiter Z-axis is in a perpendicular position to the orbital plane, enabling the RAM to strike the starboard face of the glowplate at various angles in the umbra. The SKIRT GLOS operations are continuous throughout the mission except during periods that do not satisfy lighting constraints.

- **NO PREVIOUS FLIGHTS**



---

## **STP-1 ULTRAVIOLET LIMB IMAGING EXPERIMENT (UVLIM)**

### **● DESCRIPTION**

The UVLIM contains two ultraviolet (UV) spectrometers housed in a motorized door Hitchhiker canister which protects the sensitive bare microchannel detector when not in use. The UVLIM has a plate-mounted 16mm camera installed in a pressure box for recording the visible light of stars and other objects in the experiment field of view.

### **● PURPOSE**

To study the composition of the atmosphere using measurements of the ultraviolet airglow. Sponsor: U. S. Navy Research Laboratory.



---

## **STP-1 UVLIM (CONT)**

- **OPERATION**

Following initial activation, the UVLIM door opens approximately 24 hours prior to the first data take. The crew maneuvers the Orbiter attitude during the required minimum five operating cycles. A minimum of four of these are in the limb scan mode (the Orbiter is oriented in an inertially fixed, nose/tail down attitude) and at least one is in the imaging mode (the Orbiter's X-axis is initially directed perpendicular to the orbit plane and the Z-axis is oriented horizontally in the direction of the minus velocity vector). During daylight hours, three additional imaging modes and twelve limb scan modes are described. Each limb scan requires approximately 12.5 minutes and each imaging mode observation approximately 34 minutes.

- **NO PREVIOUS FLIGHTS**





**SSP** INTEGRATION  
AND OPERATIONS

## **STS-39 PAYLOAD INFORMATION DOCUMENT**

---

# **Middeck Payloads**



**MODIFIED MODULAR LOCKER LAYOUT, STS-39  
(MIDDECK PAYLOADS)**

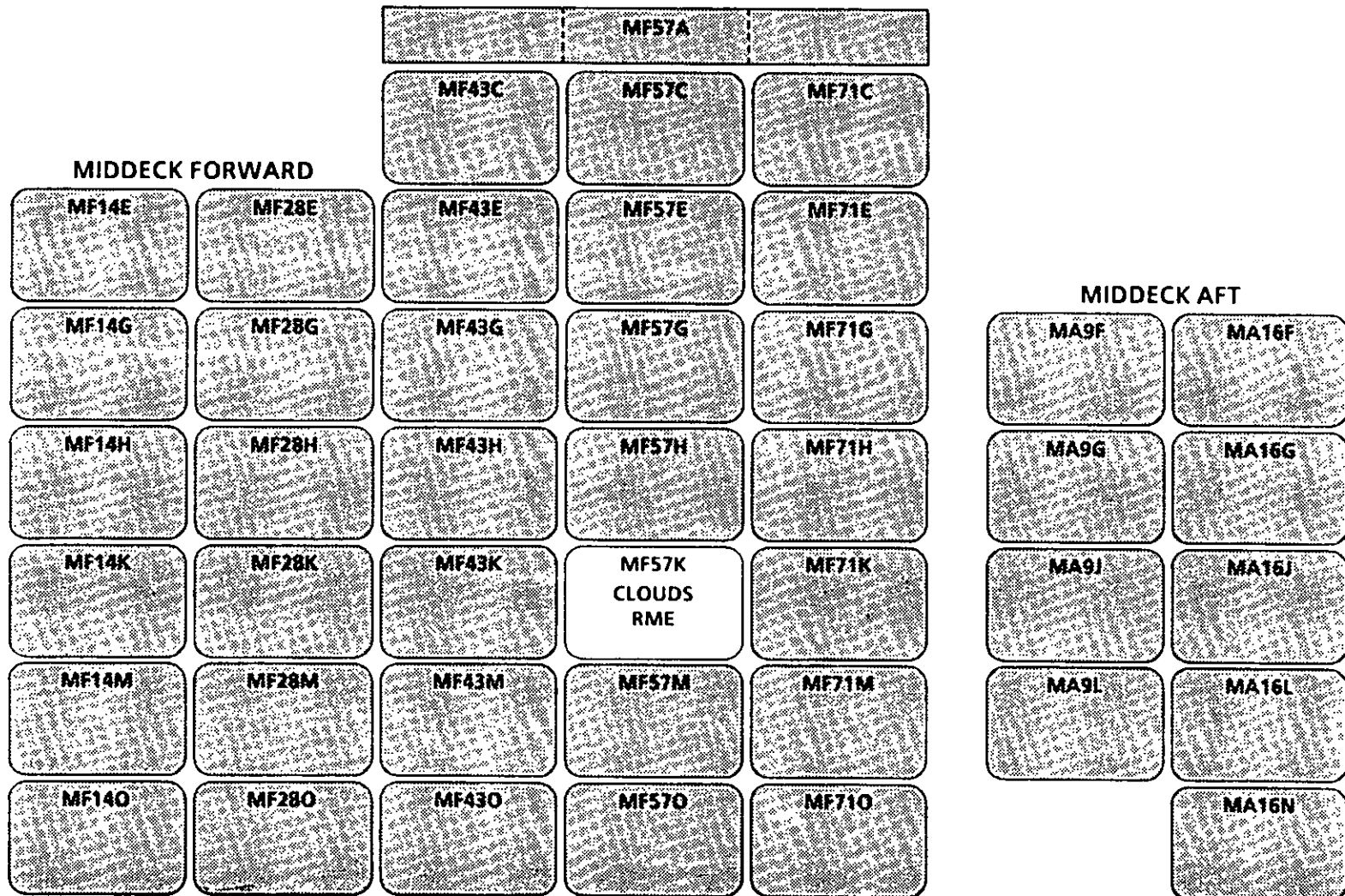



---

## **CLOUD LOGIC TO OPTIMIZE USE OF DEFENSE SYSTEMS (CLOUDS-1A)**

- **DESCRIPTION**

**CLOUDS-1A payload hardware consists of a 35mm camera body assembled with a battery-powered motor drive, a data recording system, a 105mm f/2.5 lens, a red filter, and a spare battery unit. The payload hardware will be used at the aft flight deck (AFD) station for cloud formation photography. Control weight: 4.75 lb.**

- **PURPOSE**

**To obtain photographic sequences of certain types of cloud fields; first priority is middle- and upper-layer atmosphere broken cirrus cloud fields, and second priority is lower- and middle-layer atmosphere broken cumulus cloud fields which exhibit a vertical structure. CLOUDS-1A will also include photographic sequences of cloud fields over specific ground target locations. Customer: USAF Space Systems Division.**



---

## **CLOUDS-1A (CONT)**

- **OPERATION**

Upon sighting a cloud field of interest or a specified ground location, an assigned crewmember takes photographs at 5 second intervals. The minimum data collection requirement is 4 photographic sequences of at least 20 photos per sequence. Black and white film and a red filter are used to photograph cloud fields over water. Color film is used for cloud fields primarily over land.

- **PREVIOUS FLIGHTS**

STS-27, STS-33.



**SSP** INTEGRATION  
AND OPERATIONS

# STS-39 PAYLOAD INFORMATION DOCUMENT

## CLOUDS 1A CONFIGURATION

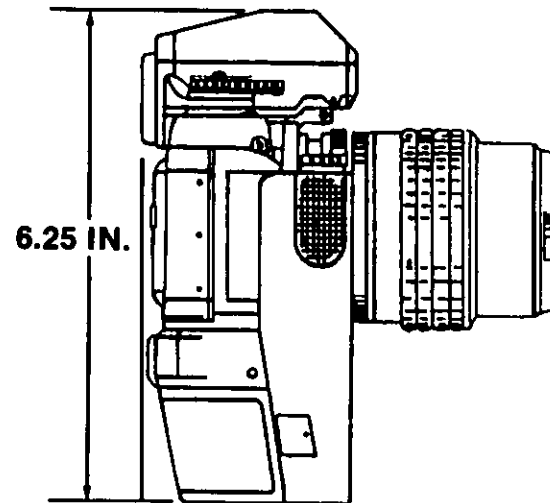
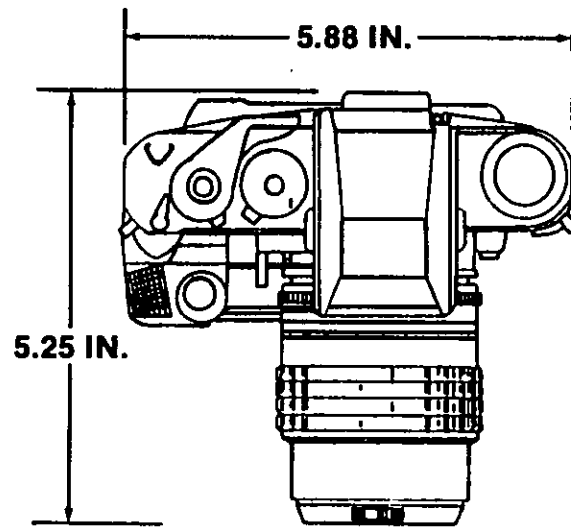
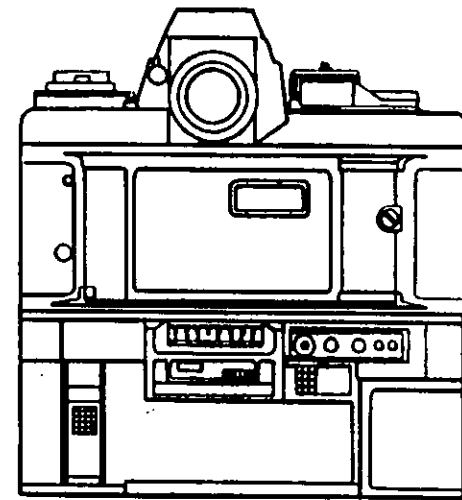
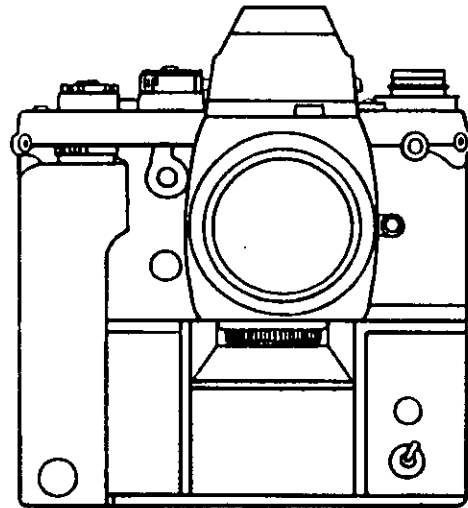



---

## **RADIATION MONITORING EQUIPMENT (RME)**

- **DESCRIPTION**

The RME is a battery-powered electronic device for measuring and recording ionizing radiation. The main module includes a keyboard and a liquid crystal display (LCD). The memory module (complement of three) attaches to the main module, and can store 32,700 intervals of data. Total control wt.: 6.9 lb.

- **PURPOSE**

To measure and record ionizing radiation exposure to the crew in the Orbiter cabin and time-tag the exposure with mission elapsed times. Customer: USAF Space Division.



---

## **RME (CONT)**

- **OPERATION**

After orbit is achieved, a crewmember unstows the RME, enters the current mission elapsed time, and verifies the setup reading on the LCD. A crewmember changes out the memory module approximately every two days. The RME is deactivated and stowed prior to deorbit.

- **PREVIOUS FLIGHTS**

STS-8, STS 41-B, STS 41-C, STS 41-D, STS 41-G, STS 51-A, STS 51-L, STS-27, STS-28, STS-33, STS-31.



## RADIATION MONITORING EQUIPMENT CONFIGURATION

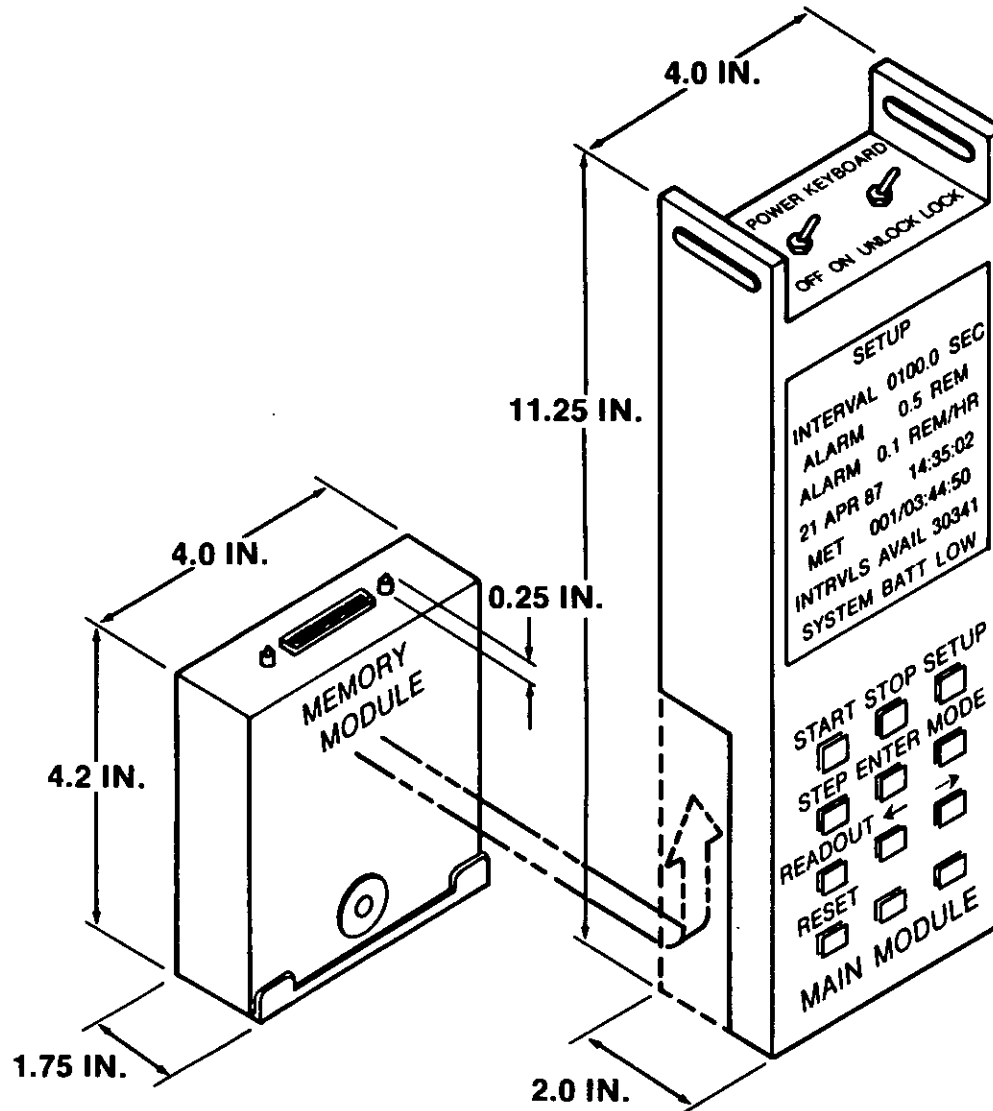





National Aeronautics and  
Space Administration  
Washington, D.C.  
20546

JAN 18 1991

Reply to Attn of.

JSC, TC12-91-001

TO: Distribution  
FROM: TA/Manager, Space Shuttle Integration and Operations  
SUBJECT: Transmittal of the STS-39 Payload Information Document

The STS-39 Payload Information Document (PID) is enclosed for your information.

The PID is a summary of the descriptions, purposes, operations, and flight histories of the STS-39 payloads, and is designed to be used for information only.

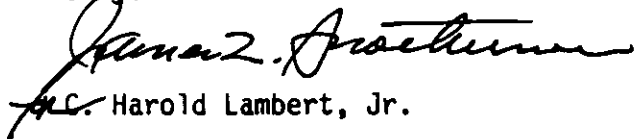
  
H.C. Harold Lambert, Jr.

Enclosure

Distribution:  
Payload Information Document Standard Distribution